

# TABLE OF CONTENTS

## THE NOTEBOOK

February, 1939 through June, 1940

FEBRUARY, 1939	PAGE
Introduction to the Notebook	1
Notice of Annual Meeting, 1939	2
Letters	
American Antiquity, a Textbook	3
Correspondence Courses	3
The "I Got" School	4
A Plains Pattern?	4
Local Groups	4
A General Bibliography	5
The Marking of Archaeological Objects, Carl E. Guthe	7
MARCH, 1939	
Annual Meeting, 1939	11
Letters	
The Notebook and American Antiquity	12
India Ink	13
And Bibliographies	14
Banner and Boat Stones	15
Preservation of Human Bones	15
Thoughts and Comments	16
Suggestions for a Beginners Library	
Ross J. Montgomery	19
Local Groups	24
Fred Dustin	24
MAY, 1939	
Program for Annual Meeting, 1939	26
Letters	
Douglas S. Byers	29
Notes on Field Preservation of Human Bone	
Donald J. Lehmer	30
Field Blank for Skeletal Material	
B. W. Stephens	31
E. T. Hall, Jr.	32
Dendrochronology	32
A Tree Ring Bibliography	36
Gertrude Hill	36
Comments Concerning Certain Minerological	
Terminology	42
David H. Howell	42
A Card Filing System for Notes and Abstracts	
H. M. Wormington	45

JUNE, 1939	PAGE
Notice	49
Letters	49
Artificial Stone as a Restoration Material	
P.F. Titterington	51
Pottery Restoration at the Milwaukee Public	
Museum Eldon G. Wolff	53

NOVEMBER, 1939	
Random Thoughts from the New Editor	
Frederick Johnson	62
Letters	
Robert M. Adams	64
Two Plastic Formulas	
H. R. Antle	66
A Proposed Outline for an Archaeological Subject	
Bibliography H. Holmes Ellis	68
Regarding Imminent or Recent Publications	
John C. McGregor	71

DECEMBER, 1939	
Notice	72
A Note from the Editor	72
Report on the Annual Meeting, 1939	73
Four Prehistoric Populations of the Middle	
West Georg K. Neumann	73
The Pound Village Site, Elgin County, Ontario	
Philleo Nash	74
A Culture Sequence from Illinois	
Horace Miner	75
The Glenwood Focus of the Nebraska	
Charles R. Keyes	76
Indian Villages Surrounding the Spiro Mounds,	
LeFlore County, Oklahoma Kenneth G. Orr	76
A Hopewell Site in Northeastern Oklahoma	
David A. Baerreis	77
Progress of the W.P.A. Archaeological Survey	
Project in Kentucky John L. Cotter	79
Symposium on Archaeological Method	
Horace Miner	79
Symposium on Ethno-History	
Fay-Cooper Cole	81
Comment on the Wheeler Method of Recording	
Harold A. Huscher	84

FEBRUARY, 1940

PAGE

Annual Meeting, 1940	90
Enclosure	91
"The Basic Needs of American Archaeology"	
Supplement Reprint from "Science", Vol. 90	
No. 2345	Carl E. Guthe
English vs Metric Systems of Measurement	94
A Practical Method for Mending Bone	
	George E. Burns
Some Ideas Regarding the Restoration of Pottery	98
	Douglas S. Byers
	98

APRIL, 1940

Program for Annual Meeting, 1940	102
The Dolly Bond Steatite Quarry	
	Ripley P. Bullen
	104
The Macon Earthlodge	Charles H. Fairbanks
	106
Preliminary Report on Cherokee County Arch- aeology	Lynn E. Howard
	107
The Neosho Focus	David A. Baerreis
	108
The Location of the Missouri Village Site	
	Brewton Berry
	110
An Outline of Southwestern Iowa Archaeology	
	Charles R. Keyes
	111
Minnesota Blade (or spearhead) Associated with Human and other Animal Remains	
	Gertrude Evans
	111

MAY, 1940

The Amateur's Outlook	W. C. McKern	114
Some Points on Bone Preservation	H. R. Antle	118

JUNE, 1940

Chemical Alteration of Archaeological Remains	Alex D. Krieger	126
Pottery Restoration	Howard Torrey	136
A Need for Terminology	Madeline D. Kneberg	138
In Retrospect	Douglas S. Byers	142
Notice		143

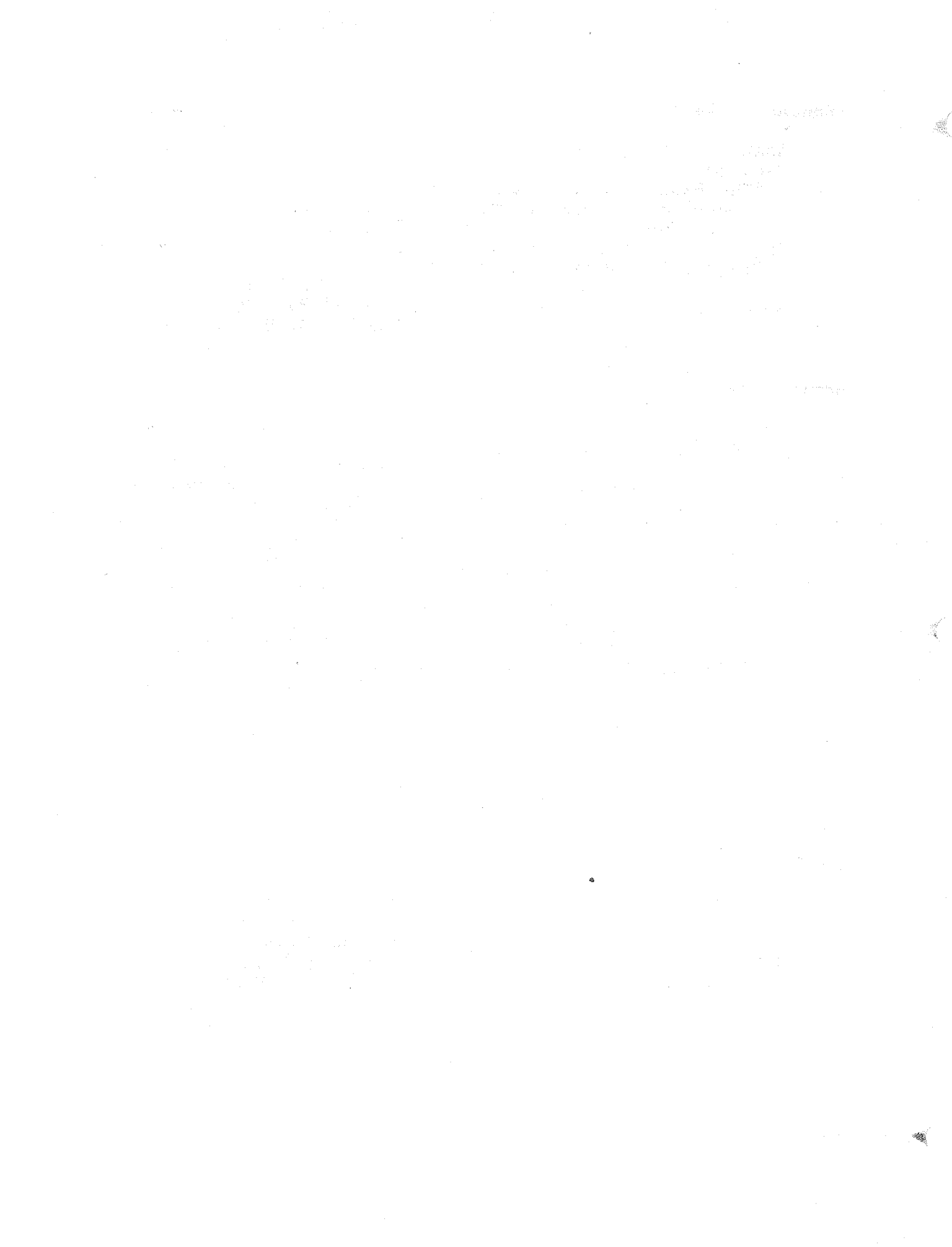

THE NOTEBOOK  
of the  
Society for American Archaeology

Article VII, Section 3, of the By-Laws:

The Society shall plan to issue a NOTEBOOK mimeographed or planographed on 8 $\frac{1}{2}$  by 11 punched paper for looseleaf filing, at irregular intervals as opportunities and circumstances permit, and containing bulletins of current interest and articles on the ways and means of archaeological research, and field, museum, and laboratory methods and equipment.

\* \* \* \* \*

One of the reasons for the founding of the Society for American Archaeology was that it might serve as a means of bringing about closer relations between the professional and the non-professional student of American archaeology. To further this end, there was written into the by-laws the provision given above. It has been necessary to delay beginning the NOTEBOOK series until it was definitely established that the Society would continue to exist, and until the income from dues of the Affiliates was sufficiently large to care for the expense of publishing "American Antiquity" as well as the cost of the NOTEBOOK. This desired condition has now been reached.

The contributions to the NOTEBOOK may consist of a single paragraph or several pages of text. The shorter contributions will be treated as letters, the longer ones as informal articles. The name and address of the author will appear with each contribution. These are omitted on these first letters, for they are extracts from correspondence not originally

intended for this purpose, and have been chosen by the Secretary-Treasurer as illustrations because of the general interest of their contents. The informal article type of contribution is illustrated by the General Bibliography, and the notes on marking of archaeological objects.

Present plans are to issue the pages of the NOTEBOOK, numbered serially, in mimeographed form on 8 $\frac{1}{2}$  by 11 paper, properly punched for insertion in a binder. If the contributions are sufficiently numerous, pages of the NOTEBOOK will be issued in those months (except August and September) in which "American Antiquity" does not appear, namely, about the 20th of November, December, February, March, May, and June. Copy should reach the Secretary-Treasurer not later than the first day of the month of issue.

The pages of the NOTEBOOK will be distributed to the mailing list of "American Antiquity."

#### Notice of Annual Meeting

By action of the Council, the 1939 annual meeting of the Society for American Archaeology will be held in conjunction with the annual meeting of the Central Section of the American Anthropological Association. The place of meeting has been established as the University of Michigan in Ann Arbor. The exact date has not been settled. It will probably be late in April or early in May. More definite information will be issued later.

This notice is an official call for titles and abstracts of papers which members care to submit for a place on the program. Those desiring to give papers will please send titles and abstracts to the Secretary-Treasurer not later than March 1. If the program can be arranged early in March, it will appear in the March pages of the NOTEBOOK.

## LETTERS

American Antiquity a Textbook

"Because of the careful field work I am doing on my village site, and the interest our local educators have in the educational and historical value of my work, I have been made Senior Instructor of Archaeology in the local Adult Education School for this section. I hope to be able to give those who are interested in our local ancient history a knowledge of what I have learned, and teach them the historic value of our ancient village sites. This may possibly help in preventing the destruction of those locations through ignorance or carelessness, and may stimulate an interest among a few members in taking up a site of their own and working carefully and correctly, or at least in helping me work mine.

"The object of writing this letter is to inquire whether the Society feels free to allow an Affiliate to take articles published in 'American Antiquity' into class rooms for reference and study. I have had few classes as yet, but already I have mentioned material from this journal, and I thought I had better write you about it before I went too far, as I do not care to infringe upon the rights of others."

Correspondence Courses

"For the past few years I have had considerable contact with a number of professional archaeologists. I have wasted a great amount of their valuable time in reading and answering my letters and in visiting many sites but I have found them unfailingly courteous and considerate, ever willing to listen and going out of their way to provide me with information and suggestions. I have attended several of the annual meetings of the Society for American Archaeology to meet on every hand evidences of good will and helpfulness without a trace of condescension on the part of anyone. I feel that I must express my appreciation for this attitude.

"I have in mind a suggestion which I would like to advance in the matter of cooperation between the professional and the amateur. If the amateur could be provided with a means of education in the fundamentals of archaeology particularly with regard to field methods I believe that the professional would be relieved of a great deal of repeated explanation and wasted time. Why not a correspondence course under the auspices of the Society for American Archaeology for its members at a price sufficient to cover the cost? I believe there are a number of amateurs who would avail themselves of this manner of obtaining information to the benefit of all concerned."

### The "I got" School

"Knowing the inner workings of those fellows' minds who belong to the 'I got' period...I feel that the only cure, or way to preserve the important vestiges is by legislation. A game-hog, whether he indulges in shooting, or fishing, or in collecting Indian material, was, and always will be the one to squeal about the laws that hamper his lust for hoggishness; and a pig when feeding - all four feet in the trough - cares nothing about the fare of his fellow kind."

### A Plains Pattern?

"What do you think of the suggestion that a third pattern be initiated to take care of the nomadic tribes of the Plains? Plains is suggested as a cultural name. Is it a good plan to give the same name to a culture and a region? Would the same confusion arise that often does when you give a cultural and linguistic term the same name? (For instance, Iroquois). Is it not true that what we know as the Plains tribes, once thought purely nomadic and derived from a hunting and nomadic people now are known, through researches of Strong et al., to be derived from a Woodland basic culture, with a transition in the Proto-Plains culture (Nebraska) and thence to the purely nomadic character that we know from historic connections?

"Would it not be a good plan to do in archaeology as we do in biology, create a sub-division of the pattern to take care of these widely divergent types? We could say Woodland pattern, Plains sub-pattern."

### Local Groups

Recently a group of individuals interested in local archaeology held a meeting. "The chief criticism with the S.A.A. was that it is too remote from immediate problems (as it must of necessity be) and that its publication is too general to answer many local problems.

"...They felt we should get together and attempt to form some group which would serve as a means of tying together the various local groups interested in archaeology, educating them in field methods, helping them with their several problems, and in general coordinating their efforts. These men are sufficiently interested in the plan to see that some such organization could provide a clearing house, and a central repository, at once receiving information and disseminating it and caring for specimens secured by society-sponsored digs. In fact this was one of the primary motives in setting up such an organization. It seems to me that such a plan is worthy of very careful consideration."





Moorehead, Warren K.,      The Stone Age in North America.  
                                  Houghton-Mifflin Co., N. Y., 1910.

A profusely illustrated two-volume description and classification of the stone implements of the North American Indians. Long out of print, this publication is now difficult to purchase. The last prices listed by second-hand book stores were in the neighborhood of \$30.00.

Shetrone, Henry C.,        The Mound-Builders.  
                                  D. Appleton & Co., N.Y., 1930.   \$7.50

A well illustrated description of the various archaeological remains found in the eastern United States.

Strong, W. D.,            An Introduction to Nebraska Archeology.  
                                  Smithsonian Miscellaneous Publications,  
                                  Vol. 93, No. 10, Washington, D. C., 1935.   \$1.50

A detailed study of the archaeological materials and problems of a larger geographical area.

Thompson, J. Eric,        Mexico before Cortez.  
                                  Charles Scribner's Sons, 1933.   \$2.50

A short, non-technical account of the daily life, religion, and ritual of the Aztec and kindred peoples of Mexico as practiced before the Spanish Conquest.

Willoughby, Charles C.,   Antiquities of the New England Indians.  
                                  Peabody Museum of American Archaeology and  
                                  Ethnology, Harvard University, 1935.   \$4.75

A description and interpretation of the archaeological objects found in the New England area.

Wissler, Clark,         The American Indian (3rd Edition)  
                                  Oxford University Press, N.Y., 1938.   \$3.75

This third edition of a standard work on all aspects of anthropological knowledge regarding the two Americas summarizes the results of specialized researches in the various divisions of this science in a concise and clear manner.

## THE MARKING OF ARCHAEOLOGICAL OBJECTS

Carl E. Guthe

Every object in an archaeological collection should be properly marked or labelled with a distinguishing symbol which may be a letter, a number, or a combination of the two. There are two reasons for labelling specimens; 1) to identify the specimen so that it may be distinguished from a similar specimen; 2) to associate the object with a catalogue or notes in which information is found concerning it.

The kind of symbols placed upon each object is determined by the method which is used in cataloguing. There are a number of different cataloguing methods, some of which use rather complex symbols. The simplest possible method is to number the objects serially, giving each one an Arabic number one digit larger than the preceding number used. These numbers or symbols should be placed upon the object in figures as small as possible, but still legible. They should be placed inconspicuously, being careful to see that the number does not appear on a surface which would normally be seen if the object were placed on display.

The method of marking or labelling, described below, is used by several museums and is particularly applicable to stone archaeological specimens. With caution it may also be used on bone, wood, and shell objects.

The materials used are a tube of Chinese Vermillion oil paint, a small bottle of quick-drying artist's oil, and a fine-pointed camel's hair brush. These may be purchased at artists' supply stores, or at stationery stores. The reason for using an oil paint is to prevent the symbol from

being rubbed off easily. The color Chinese Vermillion is used because of its brilliant red, which is easily seen on almost any colored object. Other shades of red are apt to fade into or blend with the color of reddish or brownish objects. White is easily overlooked on a light-colored object. Quick-drying oil is used to thin the small drop of paint from the tube to the proper consistency. With a little practice, a fine camel's hair brush, held in a vertical position, will make possible the painting of clearer symbols and numbers than could be accomplished by the use of a steel pen. The paint is mixed on any small flat object, such as a jar cover or saucer. Care must be taken to clean the receptacle and the brush after using. An attempt to combine new paint with old, dried paint either on the receptacle or among the hairs of the brush, will reveal that the dry paint forms small flakes and prevents making clear symbols.

Some stone objects have a very fine texture, such as very good grades of flint which have almost a glassy surface. Other stone objects are soft and porous. On the first of these, oil paint is not apt to stick very well, and on the second type, the oil paint sinks in too quickly. These difficulties may be overcome by using a coating prepared from some celluloid-acetone mixture. DuPont's Household Cement, which can be obtained in small tubes, is one of these mixtures. As it comes from the tube, it is usually too thick to form a thin coating, for it is intended to be used as a glue. It may, however, be thinned by diluting with acetone. This is a colorless liquid of the consistency of water, which evaporates very quickly. It may be obtained at chemist's stores, and must always be kept tightly corked. By mixing acetone with Household Cement

or some similar celluloid product, it is possible to secure a very thin solution of celluloid which may be brushed over the dried oil paint symbols. Since the acetone evaporates quickly, a few seconds' wait will give the symbol a thin covering of celluloid which will prevent its being accidentally rubbed off of hard, glassy surfaces.

When the stone is porous, this celluloid-acetone mixture should be applied in several coats on the spot where the symbol is to be placed, until the surface becomes sufficiently coated to permit the symbol to be placed upon it without sinking into the stone. A similar procedure may be used on objects of wood, bone, or shell. Some technicians make it a practice to cover every catalogue symbol with a thin coating of celluloid, regardless of whether the object seems to require it or not.

Experience has taught that there are a number of "don'ts" which must be observed in cataloguing articles.

1. Don't move an object which has been numbered with oil paint until you are absolutely sure that the paint has dried. Accidental rubbing together of objects, or touching wet paint with the fingers will make the symbol illegible.

2. Don't use India ink for numbering specimens. India ink may be easily washed off, and can be accidentally blurred or destroyed by damp or sweaty hands. Moreover, it is hard to read on dark objects.

3. Do not use small stickers or gummed labels for marking specimens. While they may stay in place for a short time, the gum on the back of the paper is affected by atmosphere and humidity, and will curl and drop off the specimen even in boxes or trays where the specimens are not handled at all.

4. Don't use a pencil or any other hard or sharp object for labelling specimens. Even with the greatest care, it is almost impossible to avoid scratching the surface of the object with such implements.

5. Don't label specimens with tags which are tied or wired to the specimen, or kept in place with a rubber band. The bands or strings are apt to break and the shape of the object may be such that any attachments will slip off easily. The only case in which paper tags may be used is in the field as temporary labels which are to remain with the object until the materials have reached the home or the laboratory where they may be properly labelled. When tags or slips of paper are used in the field, it is well to either wrap the object with the label inside the package, or place the object with the label in a small paper bag, so that the two may remain permanently together until removed from the container.

The marking or labelling of objects in an archaeological collection prevents confusion, makes possible positive identification in terms of notes and records, and greatly enhances the interest and the historical value of the collection itself.

The officers of the Society desire to express here their appreciation of the unanimously encouraging response which has been received about the first pages of The Notebook. Naturally, all the letters could not be used here, because of lack of space. We feel that this second group of pages demonstrates clearly a vigorous future for our Notebook.

\* \* \* \* \*

ANNUAL MEETING

Society for American Archaeology

The annual meeting of the Society will be held in conjunction with the annual meeting of the Central Section of the American Anthropological Association, in Ann Arbor, Michigan, on May 4, 5, and 6, 1939.

The titles of papers to be read at the meeting must be received by the Secretary not later than April 8, to be included in the program. A preliminary draft of the program will be included in the May pages of the Notebook which will be distributed about May first.

Carl E. Guthe  
Secretary-Treasurer  
4017 University Museums Building  
Ann Arbor, Michigan

---

 L E T T E R S
 

---

The Notebook and American Antiquity

I was very pleased to receive the first issue of The Notebook for I had thought that this splendid idea had fallen by the wayside.

At present I have only one idea to contribute and that does not seem permissible according to Article VII, Section 3, of the By-Laws, unless it is covered by the words "current interest."

My suggestion is that the type of material which is printed under the caption "Facts and Comments," Correspondence, and Notes and News in AMERICAN ANTIQUITY be transferred in part, or all, to The Notebook. This would free space for the many manuscripts which usually lie in the editorial drawer waiting their turn.

I do, however, see one objection myself in that the informal format of The Notebook does not lend itself to documentary reference.

February 16, 1939

Malcolm J. Rogers  
San Diego, California

\* \* \* \* \*

I have received the Notebook of the Society for American Archaeology and on your suggestion I am giving you my ideas briefly. I believe The Notebook to be like a private school in which many things can always be learned. In particular, I have a remark to make about AMERICAN ANTIQUITY. Everything I have read was wonderful and well in its place, but the big words used, many of them of French or Latin origin, make the study too hard for the average educated person. I know by experience if I receive something which is too difficult for me, it does not interest me.

February 18, 1939

George Petit  
Terre Haute, Indiana

\* \* \* \* \*

I believe that the Notebook suggested in your recent letter would be welcomed with enthusiasm by the members of the Society for American Archaeology. From experience I know that most of those interested in the subject have a great many ideas, methods of procedure, interesting artifacts and associated data, and most of all questions to ask, all of which would find a greatly needed chance for expression in such a publication.

Personally I shall be glad to offer some contributions for consideration from time to time. I have often felt the urge to put on paper



some things which I have come across in my investigations, some ideas which have come to mind but which I have been reluctant to submit for possible publication in AMERICAN ANTIQUITY, feeling that in such a publication they would appear too much as authoritative statements rather than as the mere ravings of a rank amateur. In The Notebook, however, such objections would be removed.

February 18, 1939

Maurice Robbins  
Attleboro, Massachusetts

\* \* \* \* \*

Received the first copy of The Notebook. I am well pleased with it.....Dr. McKern has correspondence from me on pottery restoration that might fit into the book. He wanted to use it, but this would be a better place for it. I shall send a copy of the letter. A suggestion or two: Use both sides of the paper of The Notebook, thereby increasing content without an increase in bulk. The report on the Indianapolis Conference, you recall, uses both sides of the paper quite well. Have field workers from all areas to report their methods of excavation. Make The Notebook accessible to non-members as well as members; it might save valuable specimens. Schools (public) could use it. I wonder why we cannot start a movement to introduce the use of the metric system of measurement in archaeology. This is the only remaining science that does not use this standard measure.

February 21, 1939

H. R. Antle  
Sulphur, Oklahoma

\* \* \* \* \*

India Ink

I suppose you have had a number of reactions already in regard to the first series of notes you broadcast relative to archaeology. Along with your "don'ts" you have listed India ink. Curiously, when properly applied, I have not found very much difficulty in reading identifying symbols, although I admit its use on porous objects such as hole-tempered pottery or aplastic-leached pottery is questionable. The point I wish to drive at is that "don't" should not be applied to India ink. Personally I think it rubs the fur the wrong way of even those who might be scientifically minded and is certainly not in consonance with the broad views of AMERICAN ANTIQUITY in general. I think even McKern admits there are latitudes to the application of techniques. I write this only in the spirit of cooperation. I think the whole idea of notes is excellent. By the way, when you come to pottery reconstruction, I wish you would say that there is more than one method of reconstruction.

February 15, 1939

Robert McCormick Adams  
Webster Groves, Missouri

The first issue of The Notebook has been received. This publication should prove a valuable medium to disseminate the abundance of notes and queries which every active archaeologist has on his memorandum, and to furnish much worthwhile information by which someone can benefit.

It was somewhat of a revelation to read in this issue of the Notebook "The Marking of Archaeological Objects" that pen and India ink should not be used in marking artifacts. I, and my associates in this region, have always utilized this material and upwards of a hundred thousand articles have been so marked, all unawares of your "don't". The numerals have stood up fairly well over a limit of nearly fifty years: however, most of the objects have not been handled to great extent, and always with care. Over one-half of the artifacts in this section are chipped pieces of white quartz, on which black India ink stands out clearly; but frequent renewing of pen points is required for neat work, and the surface of the article must be absolutely dry before the ink is applied, to avoid blurring.

The changing of marking methods for cataloguing seems hardly necessary with us here, but if scientifically correct to do so, we will use the plan outlined in the Notebook.

February 25, 1939

Roy Latham  
Orient, Long Island, New York

\* \* \* \* \*

And Bibliographies

I heartily approve of the plan for issuing The Notebook at intervals, thus enabling us to "get things off our chests" and to exchange ideas and helpful suggestions.

I have been finding a great deal of use for my own personal copies of AMERICAN ANTIQUITY in answering reference questions for the students at the State Teachers' College here in Flagstaff, and I feel sure The Notebook is going to serve the same purpose.

I was particularly interested in the bibliography in this issue of The Notebook, recommending books for a foundation library in American archeology. I only wish there had been more on the Southwest and its three major cultures (Anasazi, Hohokam, Mogollon), including a bit about the newly discovered sub-culture, the Pitayan. But that's probably because the Southwest is my major interest!

I found your contribution, The Marking of Archaeological Objects, a most informative one. I was exceedingly glad to have this material, for

previous experiences in marking have taught me a few things which just cannot be done. Your suggestions will be of great help in many places, I am sure.

One suggestion which I would like to offer is that The Notebook include frequent bibliographies on material pertinent to the study of archeology, such as the Folsom culture, Woodlands pattern, etc. The members of the Society with a flair for bibliography-making might have an opportunity to exercise their art in this manner.

February 16, 1939

Gertrude Hill  
Flagstaff, Arizona

\* \* \* \* \*

?? Banner and Boat Stones ??

Recently I have heard advanced the theory that both banner and boat stones were used as weights on atlatls. Do you think this would be a good subject for discussion in the Notebook of the Society?

February 14, 1939

Thomas J. Dillingham  
Boonville, Indiana

?? Preservation of Human Bones ??

I am personally interested in a formula for preserving and hardening skeletal remains which through the loss of organic matter are fragile and "chalky." We have lost much valuable material because of the well-known fact that no attempt has been made by amateur cracksmen to preserve the skeletal material reported so often in past years as "going into dust when exposed to the air." It is very probable that no attempt would have been made by the amateur to preserve the "Indian Knoll" material from Ohio Falls, for this reason; some crania comprise 75 to 100 fragments; yet I have been able to restore rather satisfactorily each cranium upon which I've worked so far.

In Los Angeles we had much mammal material from the Lompoc formation - this so "chalky" that in transporting it from Long Beach to Los Angeles, even, we often had nothing left but powdered chalk. I experimented with sodium silicate (knowing about nothing better), and we were able to preserve vertebral processes and such through this simple "water glass" treatment. At the American Museum, upon my last visit, I found that they had nothing to offer on this problem. The mammal material from the Niobrara is likewise so chalky that it is difficult to do anything with it, except

to painstakingly remove the enclosing chalk deposit by the chisel process. There is surely some better medium than "water glass" to preserve fragile skeletal material, or to so harden it that restorations capable of measurement may be made.

February 21, 1939

E. Y. Guernsey  
Bedford, Indiana

\* \* \* \* \*

Thoughts and Comments

The first pages of The Notebook are, I hope, an indication of what will be forthcoming. Certainly it gives evidence of being just what is needed to complete the coming-of-age of the amateur. Since comments are in order, here they come:

To the amateur, without very good library research facilities, sound bibliographies are extremely helpful. Why not continue with regional bibliographies which will help beginners to gain a perspective more detailed than is given in the current list, or will satisfy their interest in special fields?

A series of occasional symposia on archeological techniques and on other problems might be valuable. McKern's system of restoring pottery by building up a form of clay on a potter's wheel is quite different from our use of moulding sand, and I am sure that there are other good methods which could be set forth in a symposium on pottery restoration. Other subjects would certainly suggest themselves.

The Notebook might be a medium through which archeologists could arrive at some agreement in the matter of terminology in materials (possibly the Lithic Laboratory could referee the bout). What do various workers - including geologists - mean when they speak of flint, chert, hornstone, jasper, argillite, chalcedony, rhyolite, or obsidian? What defines one material or the other? In quite another field, what traits define the several fundamental patterns and phases in the McKern system? What is Woodland and what is Mississippi? I have the impression that there is some disagreement on these points.

A word on the use of legislation to prevent the destruction of archeological sites by amateur and commercial collectors. I for one cannot see such legislation as a cure-all, or even as very desirable in some places.

And now for a question of my own: What would be the standing of surface evidence?

I am certainly not going to contend that the evidence gained by competent excavation is not immeasurably superior to the suggestions from surface gleanings, but I do think that surface collecting is a neglected and maligned tool which is particularly adapted to the resources of the average amateur, and which should be given the benefit of statistical study.

There seem to be two main arguments against surface evidence: first, that surface collections do nothing to prove associations, since the specimens found may have been dropped at any time during or after the occupation of the site; and second, that there is a tendency to collect only perfect specimens, thus giving a completely false idea of relative frequencies and possibly eliminating some traits completely.

To the first argument I would say that a surface collection can be just as valid as some hurried excavations conducted chiefly to amass material relics, except that in the latter case you do know that the pieces were all under ground when found. I believe that by examining all the surface material from a given site, especially if there is a great deal of it, it should be possible to make out trait and even frequency tables which will tell the truth, if not the whole truth. By combining the findings of several collectors, such a study would become more valid statistically speaking, and might well approach the accuracy of a trait table gained through prolonged and expensive excavation. Certainly, by comparing such a surface chart with the established trait tables for various cultures, it would be possible to identify the provenience of the surface material and present valuable information as to distribution, etc., of said traits and cultures. Moreover, if the mixture of unrelated artifacts from a stratified site or the intrusion of one culture on another did occur, the surface traits would fail to match the established complex, and the obvious conclusion would be that the site should be examined more

closely. Such an anomaly might mean a mixture, or it might mean a new focus or even aspect, and in either case thorough investigation would be indicated and would reveal the truth, the whole truth, and nothing but the truth. The chances are pretty small that a chance mixture of specimens from two cultures would produce the traits of a third and present a wholly false picture.

As a matter of fact, the case seems to me to be exactly analogous to intelligence testing in education. Group tests give a general picture, but if anything abnormal appears, such as a very low I.Q., an individual test is administered by an expert to check the original finding and supplement it.

On the second score, let me say that supposedly competent excavators have been known to catalogue only perfect specimens and neglect all else in preparing their reports, while there are plenty of farmers who pick up broken pieces as well as good ones, and keep them segregated by site, to boot. The more collections you include in your survey of a site, the more apt it is to give a fair sampling.

Actually, the whole question seems to be a statistical one - a matter of sampling. Valid or not, most of our information about some parts of the country is going to come almost entirely from surface finds, and it behooves us to find out how to get the most out of them instead of looking them over with a raised eyebrow and passing by. I object strongly to the feeling that surface material should be used to confirm an hypothesis evolved from excavations, while the reverse process is unclean and unholy. Practically speaking, it may be the more usable of the two.

The S.A.A. has taken a big, and I hope fruitful step in recognizing the real importance of what the amateur student can do. It seems to me that it might urge the second step of recognizing the value of the amateur's chief tool, surface hunting, and make an honest effort to determine how that tool can best be used.

February 18, 1939

P. Schuyler Miller  
Scotia, New York

## SUGGESTIONS FOR A BEGINNER'S LIBRARY IN ANTHROPOLOGY

By Ross J. Montgomery  
Los Angeles, California

When, five or six years ago, I decided to instruct myself as best I could in such departments of anthropology as a layman might enjoy, I experienced discouraging difficulties in making a discriminating selection of books. After floundering around without guidance or orientation upon a trial and error basis, I finally got together a library that covered, it seemed to me, a comprehensive introduction to anthropology, with emphasis on certain phases of American archaeology. Experience taught me that it was best to buy one book at a time, and to read it through from cover to cover, including footnotes and appendices, if any, before the next book was purchased. By such procedure, and by procuring and reading certain publications recommended in bibliographies as found sometimes at the close of worthwhile books, I developed a fair sense of discriminatory judgment in the choice of publications.

During the initial floundering period, trashy books padded with generalities and amorphous subject matter found their way onto my book shelves. This particular period of patronage extended to unscientifically trained authors with obvious commercial leanings, fortunately was short-lived. From the time of my first interest I've read, exclusive of bulletins and pamphlets, an average of at least twenty-five books a year on anthropological subjects; have never done any field work, however, probably never will; and have no aspirations to write nor to collect "Indian curios." Strictly speaking, I'm an unmitigated armchair amateur of archaeology. My primary life interest is architecture; therefore the design and construction of buildings keeps me constantly occupied, except of course when the customary hours usually devoted to relaxation are at my disposal.

However, to the point: You are to be congratulated in stepping out in print with a "General Bibliography" of twelve books for the beginner in American archaeology. This is one of the first attempts I've found to help the floundering layman of good will, ignorant though he be. Now I'd like to submit an alternate list of books for the tyro, for it seems to me your list excludes the study of the fundamental prerequisites on which archaeology as a science is founded. Then, too, it seems best to get a world anthropological picture before one gets busy exclusively with Western Hemisphere matters. What do you think of the following lists?

General

1. Textbook of Physical Geology, Longwell, Knopf, & Flint -(J.Wiley & Sons)
2. Textbook of Historical Geology, Schuchert & Dunbar - (J. Wiley & Sons)
3. An Introduction to Physical Anthropology, E. P. Stibbe -(Longman, Green Co.)

4. Early Man, edited by George Grant MacCurdy (Lippincott)
5. Human Origins (two volumes) - George Grant MacCurdy (D. Appleton Co.)
6. Source Book in Anthropology - Kroeber & Waterman (Harcourt, Brace & Co.)
7. Anthropology - A. L. Kroeber (Harcourt, Brace & Co.)
8. They Wrote on Clay - Edward Chiera (University of Chicago Press)
9. The Conquest of Civilization - James Henry Breasted (Harper & Sons)
10. Wonders of the Past, edited by J. A. Hammerton (4 volumes), G.P. Putnam's  
 Note: Any one article in these books is sketchy and trivial. Sons  
 However, if all four volumes are taken en bloc, the collected  
 data present an archaeological picture well worth reading for  
 the non-specialist.
11. Children of the Yellow Earth - J. Gunnar Anderson (Macmillan Co.)
12. The Birth of China - Herrlee Glessner Creel (Reynal & Hitchcock)
13. Peoples of Asiatic Russia - Waldemar Jochelson (American Museum publication)
14. Source Book for African Anthropology - W. D. Hambly (Field Museum pub.)

Western Hemisphere: General

1. The American Indian (3rd edition) - Clark Wissler (Oxford Univ. Press, N.Y.)
2. American Aborigines - D. Jenness, editor (Univ. of Toronto Press)
3. The Mound-Builders - Henry C. Snettrone (D. Appleton Co.)
4. Landa's Yucatan - The Maya Society
5. Ancient Civilizations of Mexico and Central America - Herbert J. Spinden  
 (American Museum pub.)
6. Ancient Civilizations of the Andes - Philip Ainsworth Means (C. Scribner's  
 Sons)

From here on, the tyro can specialize in one particular cultural area, according to his predeliction; let us say, for instance, in the Southwest and its periphery; here are a few anthropological publications pertaining to this specific field, selected from among many, which the intelligent novice can understand and enjoy:

1. A Survey of Southwestern Archaeology - F.H.H. Roberts, Jr. (Smithsonian Inst.)
2. Archaeological Explorations in Northeastern Arizona - Kidder & Guernsey
3. Excavations at Snaketown, Medallion Papers No. XXV, Gila Pueblo, Globe.  
 (Vol. 1 only. The tyro should never read the second volume. He might  
 run berserk.)
4. Basket Maker Caves of Northeastern Arizona - Guernsey & Kidder. Report  
 on the Explorations of 1916-1917, Peabody Museum, Harvard.
5. Symposium on Prehistoric Agriculture - University of New Mexico Press.
6. Ibero-Americana, Vol. I - University of California Press
7. Gypsum Cave, Nevada - M. R. Harrington (Southwest Museum publication)
8. Archaeology of Pleistocene Lake Mohave, A Symposium - (Southwest Museum)
9. The Relation of North American Prehistory to Post-Glacial Climatic  
 Fluctuations - R. G. Fisher (University of New Mexico Press)



10. Essays in Anthropology (Presentation to Dr. Kroeber, 1936)-(University of California Press)
11. Hopi Economic Life - Earnest Beaglehole (Yale University Press)
12. Navaho Warfare - W. W. Hill (Yale University Press)
13. The Significance of the Dated Prehistory of Chetro Ketl - Florence M. Hawley (University of New Mexico Press)
14. Navaho Weaving - Charles Amsden (Southwest Museum publication)
15. Yuman Tribes of the Gila River - Leslie Spier (Univ. of Chicago Press)
16. The Tarahumara - Bennett and Zingg (Univ. of Chicago Press)
17. Eighth Annual Report of the Bureau of American Ethnology (Smithsonian Institution) -"A Study of Pueblo Architecture; Tusayan and Cibola" by Mindelleff.
18. Indian Basketry - Otis T. Mason (Report of U.S. National Museum, 1902)

I think it is a mistake to switch the tyro back and forth between one cultural area and another. Such books as Strong's "Nebraska Archaeology," Willoughby's "Antiquities of the New England Indians," and "Re-Discovering Illinois" by Cole and Deuel, should each be segregated and added to kindred subject matter for those particularly interested in the Northern Woodland or Plains areas. If the beginner thinks he has to cover the entire field, even within the confines of the states, he will be discouraged somewhere along the line. I am of the strong opinion that there are few, if any, archaeologists or ethnologists who have more than a cursory knowledge of any cultural area other than the one in which they have specialized, and God knows, a limited field is a lifelong job in itself.

Therefore, it seems logical not to expect the self-taught student to master a comprehensive technical picture of all cultural areas within the confines of the U.S.A. or any other place, when the savant with his university background and field experience, can't do it himself. The truly technological literature recommended for the amateur should be confined to one cultural area with its manifold ramifications. If he can take the mental punishment and has the patience to grub out some essential facts pertaining to any one of these centers of influence, he has gone far. I imagine that most self-taught "anthropologists" in a "vocational" sense, wonder now and then how and where anthropology fits into the pragmatic objective world about us, as a practical science. When in this state of frustration, it is time to read a few books bordering on social anthropology, as for instance the following:

1. Middletown in Transition - Robert and Helen Lynd (Harcourt, Brace & Co.)
2. China at Work - Rudolf P. Hommel (The John Day Co.)
3. Hooton's more popular books
4. Materials for the Study of Inheritance in Man - Franz Boas (J.J. Augustin)

I think the novice should subscribe to the "American Anthropologist," "American Antiquity," and some quarterly or monthly majoring in the Classical and Oriental fields, and he should not only subscribe thereto, but should read every article as set forth in all issues. He might be forced to forego some paper occasionally if published in German or French, unless versed in one or both of these languages, but he should discipline himself to wade through the remainder with serious concentration. Some of the articles may seem musty to the casual reader, no doubt; other papers, from the viewpoint of one untrained in certain scientific technics and objectives, may seem apparently irrelevant, but collectively they will help to keep the world picture in mind. The retention and awareness of this mental "world picture" is of vital importance to the beginner if he is trying simultaneously to unravel significant factors from texts limited in scope to a specific cultural horizon. Most assuredly, it is tragic if the forest can't be seen for the trees, and it is even more tragic if the beginner is grounded by the confusion engendered by localized minutiae.

And here it may not seem irrelevant to mention what to me has been a proved antidote for the frightfully serious scientific tomes and papers which one has to mill through. Abstracting from certain physical anthropological problems and phases of ethnological and social media, almost every anthropological path in the New World seems more or less to lead up to, or back to the Discovery. Fourteen ninety-two apparently focuses the attention equally with A.D. and B.C. in your literature. I've therefore found historical data to be the antidote in question. On my armchair Western Hemisphere reconnaissance in anthropology, with emphasis on the Southwest, I've found among other pertinent historical treatises, the following books of special value, which have helped in blowing off mental steam and preserving equanimity:

1. Fall of the Inca Empire - Means (Scribner's)
2. Discovery and Conquest of Mexico - Diaz, Introduction by A. P. Maudslay (Routledge)
3. The Conquest of Yucatan - Blom (Houghton, Mifflin Co.)
4. The Colonization of North America, 1492-1783 -Bolton & Marshall (Macmillan)
5. New Spain and the Anglo-American West, A Documentary Collection in two volumes, presented to Dr. Bolton (Lancaster Press, Pa.)
6. History of New Mexico - Villagra-Quivira Society Publication
7. Forgotten Frontiers - Thomas (University of Oklahoma Press)
8. Spanish Exploration in the Southwest, Original Narratives edited by Dr. Bolton (Scribner's)
9. On the Trail of a Spanish Pioneer; Garces Diary, two volumes, Coues (Francis P. Harper Co.)
10. Palou's Life of Junipero Serra, edited by James (published in Pasadena)
11. Outpost of Empire - Bolton (Alfred A. Knopf)
12. Rim of Christendom - Bolton (Macmillan)

13. History of Hawikuh - Hodge (Southwest Museum publication)
14. Story of the Missions of the Middle Southwest -Lockwood (Fine Arts Press, Santa Ana)
15. Missions and Pueblos of the Old Southwest - Forrest (Arthur H. Clark Co., Glendale, Calif.)
16. Missions of California - Zephyrin Engelhardt, O.F.M. (James H. Berry Co., San Francisco)
17. The Dominican Mission Frontier of Lower California - Meigs (Univ. of California Press)
18. History of California; Spanish Period - Chapman (Macmillan)
19. The Letters of Cortes to Charles V - MacNutt (Arthur H. Clark Co., Glendale, Calif.)
20. The Coronado Expedition, 1540-42 - Winship (14th Annual Report, B.A.E.)
21. Inca Treasure - Lothrop (Southwest Museum publication)
22. Handbook of American Indians, edited by Dr. Hodge - Bulletin 30, Parts 1 and 2, Bureau of American Ethnology. Should be in every beginner's library as Source Book No. 1.

No attempt has been made by any means to list all archaeological, ethnological, or anthropological books and papers found on my library shelves. I've merely tried to enumerate such publications as might be of initial value to the prospective adult student, whose latent interest is aroused, and who intends to educate himself as best he can from scratch. The list, of course, would be of special interest to the Southwesterner.

It would be interesting to hear from others on the subject of an anthropological library for adult beginners, or for that matter, about anthropological libraries in general.

\* \* \* \* \*

## LOCAL GROUPS

By Fred Dustin  
Saginaw, Michigan

On page 4 of The Notebook, "Local Groups" are discussed. Having been a participant in one of these for several years, as well as an original member of the now dormant Michigan State Archaeological Society, perhaps a few words from experience on the subject will not be out of place.

Several years ago, in part through acquaintances formed through the Archaeological Society, a few men interested in Michigan archaeology met at the residence of one of them, for an exchange of experiences, with the idea that information possessed by individuals might be passed along to others. There was no formal organization, nor has there been since; no regular meetings, but from time to time at their convenience, the members have invited the group to their homes for an evening and these little gatherings have been profitable. Resulting from these irregular meetings, we have had five or six field days, in which we journeyed to notable prehistoric sites, did some collecting, and enjoyed a lunch in the open, perhaps before a small camp fire if the weather was cool, and returned home refreshed and happy.

Another result has been a quickened interest, and a more intelligent study of prehistoric days and ways. Specifically, one of our number, a supervisory official in a large city post office, has so extended his interest that he has made trips to Central America and Canada to look over certain ruins in the former and notable sites in the latter; but what seems to me, under the circumstances, more important, he has taken a very active part in a newly-organized County Historical Society and is now President of it. He has also written a paper from first-hand information concerning the meaning and use of the totemic figures commonly called "bird-stones," which has appeared in AMERICAN ANTIQUITY.

Another member, an expert photographer and artist, who has a fine general collection, has taken many pictures of objects and artifacts and has produced some fine, correctly colored casts of bird-stones. Although he does not know it, he is our best conversationalist, and is too modest to believe it.

A third, a young business man, has done unusually good work in research in the southern part of Saginaw County, locating about seventy prehistoric village and camp sites, accurately plotting them on a map of his own making, and identifying each by a specific number according to a system used for many years by one of the group. His work is in line with the information which has already appeared in that monumental work by Dr. W. B. Hinsdale and Edward J. Stevens, the "Archaeological Atlas of Michigan."

Another young man in the postal service has made a collection of Indian artifacts, pottery, and other remains, gathered in the field by his own hands. He has constructed a large cabinet in which most of his collection is systematically arranged, and in addition he has also many fine pieces displayed on lighted shelves, where he also shows an unusual cache of chert blades discovered by him some years ago.

One of our members is a physician, who has developed a legitimate "hobby" in the collection of Indian material, almost all of which is stone weapons, implements, and ornaments. There are two unusual cache collections, a large collection from Tuscola County, Michigan, and a collection of arrow-points gathered by a man who was preparing a paper on the minerals used by the Indians in making arrow-points, and representing type materials from thirty-eight states. So enthused did he become that he has had special lighted cabinets constructed, as well as exhibit and storage cases matching the cabinets, all in a fine, large room in his residence.

The last member to be mentioned, a young farmer in the extreme north part of Bay County, has a collection that began in boyhood days, and each year he has increased it. He, too, has done splendid work in discovering and recording prehistoric sites, and his specimens, gathered by his own hands, would alone form a notable museum collection or exhibit. His intelligence and understanding were gladly availed of by Dr. Hinsdale in the preparation of the Atlas before mentioned, for the rough draft of Bay County was prepared by him. His specimens are so marked that he can tell at a glance where they were found, and his system of marking conforms to that of the other collectors of the group. His papers, although unpublished, are fine productions, blending early and later experiences in the field with touches of sentiment and memories.

Our group has not "thrown open its doors," so to speak; we have realized that while a passing curiosity may grow into an active one, a discrimination in inviting possible "joiners" has been exercised, so that very few - not more than two or three - have been added to the original four or five who first met. At the meetings some papers have been read, articles exhibited, and informal talks given. Occasionally one or two have been invited as guests for the evening. While we do not set a pattern for others, we feel that a congenial fellowship of a few is better than a formal organization which would require a regular meeting place with the attendant expense, although, naturally, if a considerable number felt a sufficient interest, an organization would be useful.

\* \* \* \* \*

The following tentative program for the joint meetings of the Central Section of the American Anthropological Association and the Society for American Archaeology is given for your information. We hope that many Society members will find it interesting, and will plan to attend the sessions held in Ann Arbor, Michigan, on May 5 and 6, 1939.

FRIDAY, MAY 5

Morning Session, 9:30 A.M.

Section A, Amphitheatre  
Rackham Building

Four Prehistoric Populations of the Middle West (illustrated) -Georg K. Neumann, University of Michigan  
Rambling Comments on the Fort Ancient Aspect and Related Cultures - James B. Griffin, University of Michigan  
A Geologically Dated Camp Site, Georgian Bay, Ontario: Part 1, E. F. Greenman; Part 2, George M. Stanley, University of Michigan  
The Pound Village Site, Elgin County, Ontario (illustrated) - Philleo Nash, University of Toronto  
A Cultural Sequence in Illinois - Horace Miner, Wayne University  
Prehistoric Drouths in the Mississippi Valley - Florence Hawley Senter, University of Chicago

Section B, East Lecture Room

Ancient and Modern Man in Iran (Illustrated) - Henry Field, Field Museum  
Culture Contact in Syria (illustrated) - Anne H. Fuller,  
A Technological Study of the Unglazed Pottery and Figurines from Seleucia-on-the-Tigris - F. R. Matson, Jr., University of Michigan  
Money in the Economics of Primitive Societies - Melville J. Herskovits, Northwestern University  
Dual Systems of Descent in West Africa - Wm. R. Bascom, Northwestern University

Afternoon Session, 2:00 P.M.

Section A, Amphitheatre  
Society for American Archaeology  
President Edgar B. Howard, Presiding

The Glenwood Focus of the Nebraska - Charles R. Keyes, State Archaeological Society of Iowa  
Two "Woodland" Manifestations in Nebraska (illustrated) - Stanley Bartos, Jr., University of Nebraska  
A Late Contact Site of the Oneota Aspect (illustrated) - Henry Angelino, University of Nebraska

- A Preliminary Report of the Archaeological Remains of the Ponca Indians  
(illustrated) - Genelle Jenkins, University of Nebraska
- A Preliminary Note on the Possible Genesis of the Upper Republican Culture -  
Earl H. Bell, University of Nebraska
- Indian Villages Surrounding the Spiro Mounds, LeFlore Co., Oklahoma (illust-  
rated) - Kenneth G. Orr, University of Oklahoma
- A Hopewell Site in Northeastern Oklahoma - David Baerreis, Grove, Oklahoma
- Business Meeting of the Society
- - - - -

Section B, East Lecture Room

Symposium on Ethno-History. Dr. Fay-Cooper Cole, presiding

- - - - -

6:15 P.M. Dinner at Michigan League. Speaker, Dr. Fay-Cooper Cole

8:00 P.M. Evening Lecture  
Amphitheatre, Rackham Bldg.

Speaker, Wendell C. Bennett, University of Wisconsin, "Some Problems of  
Peruvian Archaeology."

SATURDAY, MAY 6

Section A, Amphitheatre

- A Carved Stone from D'Arcy, Saskatchewan - V. A. Vigfusson, University of  
Saskatchewan
- Ecological Conditions in New England - Douglas S. Byers, Phillips Academy,  
Andover
- Tentative Correlation between Archeological Discoveries and Ecological  
Conditions in New England - Frederick Johnson, Phillips  
Academy, Andover
- Progress of the W.P.A. Archaeological Project in Kentucky (illustrated -  
John L. Cotter, University of Kentucky
- A Problem of Natural vs. Cultural Strata solved by Tree-ring and Potsherd  
Analysis - Donovan Senter, University of Chicago
- The State-wide Archaeological Survey of Texas - George R. Fox, Graham, Texas
- Business Session, Central Section, A.A.A.

Section B, East Lecture Room

Saturday Morning session  
May 6, 1939 - 9:30 A.M.

The Position of the Great Basin in North American Ethnology - Willard Z. Park,  
University of Oklahoma  
A Civil Function of the Buffalo Police among the Ponca - Earl H. Bell,  
University of Nebraska  
A New Perspective in Siouan Affiliations - Carl F. Voegelin, DePauw University  
The Development and Regional Background of the Shawnee Burial Complex -  
Erminie W. Voegelin, Greencastle, Indiana  
European Civilization as a Determinant of Native Indian Customs - W. Vernon  
Kinietz, University of Michigan  
Indian Myths and Superstitions about Lake Superior Copper - Charles E. Brown,  
State Historical Museum, Madison, Wisconsin

Afternoon Session

Amphitheatre

2:00 P.M.

Symposium on Archaeological Methods - W. C. McKern, presiding.

\* \* \* \* \*

Notes:

Papers limited to twenty minutes.  
Registration desk and information at the Rackham Building.  
Reservations for rooms may be made at the Michigan Union or  
the Michigan League, at both of which cafeteria and dining  
room service are available.



LETTERS

The letter from E. Y. Guernsey of Bedford, Indiana, published in the last number brings to mind a number of processes for hardening bone artifacts or skeletal material with varying degrees of success. We have been faced with the problem of dampness in addition to fragility.

To drive out moisture we have placed our bone in alcohol if it could be handled; or if it was too fragile to stand transfer to treating tanks, we have poured alcohol directly on the specimen in the ground. While this will not drive out all the water, it will drive out some of it.

As a hardening medium we have used a solution of celluloid in acetone, or very thin ambroid. Both turn white when in contact with moisture. Tank-treated specimens are placed in the shade for the alcohol to evaporate before being dipped in the hardening medium. Specimens left in the ground are treated by painting the ambroid or colloid right onto the specimen, forming a white skin over the exposed part, and strengthening it enough to permit turning it over to allow cleaning of the under side. Specimens can be cleaned with acetone or with the same solution when one returns from the field. They may be dipped again to ensure complete impregnation.

Gum arabic might be used in a dry climate. Bone from Cocle was brought back to the laboratory in gum arabic with lots of bandages around it. This will mix with water and can be used on wet specimens without drying them out. It is not recommended in a climate like the New England one along the coast. On Martha's Vineyard we attempted to save some sherds by this method, but we had to bring them to the house and put them in the oven to dry out. The Cocle bone was handled with great care; the excess gum arabic was washed off in water and the whole thing dipped in thin ambroid. But in general it seems that gum arabic is harder to handle and I cannot say how it acts if one attempts to mend a broken object with Duco Cement or ambroid, or to use plastic wood for repairs.

Mr. Guernsey should have no trouble with chalky bones if he dips them directly into thin ambroid, liquid celluloid, or a thin solution of Alvar 7-70. Anything of this sort will contract to a certain extent, but our Maine specimens have come through in good shape.

Alvar, by the way, is soluble in "any of the alcohols," to quote a letter from the sales manager. This should be a cheaper medium than ambroid, or celluloid in acetone, and would have the advantage of mixing perfectly with alcohol in specimens dried in an alcohol bath. It may be obtained from the Shawinigan Products Corp., Empire State Bldg., N.Y.C. We have had no experience with it in the field.

These media might be expensive for mammalian bone or for large quantities of skeletal material. We found it not too expensive to use ambroid in Maine on skulls and on bone artifacts. The only drawback to this method is that alcohol and water eventually creep into the thin ambroid, turning it white and making it "curdle" or separate. With dry specimens one would not face this difficulty.

March 28, 1939

Douglas S. Byers  
Andover, Massachusetts

- \* \* \* \* \*

#### Notes on the Field Preservation of Human Bone

In the American Journal of Physical Anthropology, Vol. XXI, No. 3, Dr. George Woodbury of the Peabody Museum describes a method of preserving human bones by the use of "Alvar" (polyvinyl acetal) in solution in acetone. His description of the method of laboratory treatment is very thorough, and it has been found excellent in practice.

To his remarks a few notes on a field technique developed during the course of work on a village site near Presidio, Texas, may be added.

The skeletal material found is in an extremely fragile state, and deteriorates rapidly on exposure to air. It has been found, however, that a coating of the "Alvar" solution applied while the bones are still in situ will preserve them until proper laboratory treatment is possible.

Immediately upon exposure, all fine particles of dirt adhering to the bones are removed, and they are saturated with acetone (U.S.P.) applied with a soft brush. When the surface is almost dry, a light coating of "Alvar" is brushed on and others added from time to time. When the solution has thoroughly dried the bone is removed from its original position and is placed on a square of absorbant cotton with the treated side down. The same procedure is then applied to the other side. It is found best to photograph the burial while the original coating is drying.

The layers of Alvar form a protective coating over the exterior of the bone which prevents escape of moisture and provides sufficient surface tension to prevent breakage during shipping or handling if proper care is exercised. The preservative may be removed in the laboratory by brushing well with acetone. When the field coating has been removed, the bone is soaked first in acetone and then in the Alvar solution until saturated as described in Woodbury's article. For laboratory treatment, Woodbury advises a 20% solution, but for field usage a 25% to 35% solution (by volume) is recommended.

March 29, 1939

Donald J. Lehmer  
Presidio, Texas

February 21, 1939

B. W. Stephens, Quincy, Illinois

I am enclosing a Field Blank for Skeletal Material that might prove helpful. This is very similar to the blank used by the Department of Anthropology of the University of Chicago. On the back of the form, the mound is plotted off on squares.

FIELD BLANK FOR SKELETAL MATERIAL

I. GENERAL DATA

Field number:

Site number:

Date discovered:

Exposed by:

Photograph numbers:

Sketch (over) check here:

II. STRATIGRAPHICAL DATA

Type of soil above burial:

Evidence of being intrusive:

Depth in relation to datum plane:

Depth below surface of mound:

Location (in square #):

Triangulation:

III. ETHNO-ARCHAEOLOGICAL DATA

Type of burial:

Associated objects:

Position: A. Right arm

B. Left arm

C. Right leg

D. Left leg

E. Trunk

F. Head

Posthumous shifting of bones:

General description of burial:

IV. OSTEOLOGICAL DATA

Age:

Sex:

Posthumous deformation:

Bones broken:

Bones absent (or present):

Pathology:

Measurements and observations on bones in a poor state of preservation (before removal):

D E N D R O C H R O N O L O G YThe Need for a Dendrochronologist as an Active Member of  
Field Expeditions

Development and perfection of tree-ring dating by Dr. A. E. Douglass, in 1928 (1), revolutionized many theories concerning southwestern archaeology. Since that time it has been a practice of expeditions in this area to collect wood and charcoal during excavation to be sent to one of the institutions actively engaged in tree-ring dating. (2) It was a matter of course that this work, for effective results, should be done in the laboratory. As a rule expeditions in the field have not included a dendrochronologist, a person trained in the methods of dating wood and charcoal. While actual dating of large groups of specimens is most certainly accomplished to better advantage in a laboratory, the close relationship between field collecting and indoor work heretofore has rarely been sufficiently stressed (3). There have been instances where a tree-ring man has conducted his own excavation and, later, dated the material himself; in such instances there has seldom been any difficulty in obtaining dates. On the other hand, in some cases of material sent in for dating which had not been excavated by a trained tree-ring worker, no dates were obtained. This was due, usually, not to lack of specimens submitted, but to a lack of datable specimens.

Due to the relative accuracy of tree-ring dating in comparison with other methods of dating sites, and to the importance attached to tree-ring dates, the care and selection of tree-ring specimens should constitute one of the main objectives in any excavation. The collection of datable material from any site is as important, if not more so, as any other phase of archaeological work, such as house and burial excavation and the making of stratigraphic tests. For this reason the proper handling of wood and charcoal cannot be overstressed.

Accuracy in dating specimens is largely dependent on the ability to establish the cutting date. To do this the outside surface must be preserved. Charcoal represents a large proportion of the material encountered and requires extra care, due to its extremely friable and fragile nature. If rings from a piece of charcoal are lost, it is impossible for the dendrochronologist to determine the date at which the tree was cut. Even in careful excavation the exterior surface of charcoal specimens is often lost. In the case of careless excavation this surface is seldom preserved. Charcoal, like skeletal material, requires special treatment in excavation and packing and should not be entrusted to other than trained workers.

While the writer has used various methods in removing whole specimens from the ground, including the use of air pumps and soft brushes, it may be seen that to excavate all of a burned roof in this way would run

into prohibitive cost, were not a short cut possible. The short cut is the ability to select useful specimens from non-useful ones at the site. Whenever, as it sometimes happens, a large proportion of timber used in the construction of prehistoric sites is undatable, a dendrochronologist at the site can devote his energy to datable specimens, thus saving valuable time that would be wasted by a less experienced person.

Juniper (Juniperus utahensis, J. monosperma, etc.), cottonwood (Populus deltoidea), scrub oak (Quercus gambelii, Q. fendleri, etc.), and mountain mahogany (Cercocarpus montanus) are not normally datable woods. Western yellow pine (Pinus ponderosa), douglas fir (Pseudotsuga taxifolia), and the pinyon (Pinus edulis and P. monophylla) are ordinarily readily dated. Whether in the form of wood or charcoal, a dendrochronologist is able to identify all of these species at sight.

Juniper was probably the most commonly used wood in prehistoric sites, especially in early constructions where no great span was required. Due to the large amounts of juniper sent in each year, the practice at the laboratory has been to save a few specimens in good condition, in the hope that someone, some day, will work out a juniper chronology. The careful field man, fully aware of the importance of tree-ring specimens, yet unable to distinguish between desirable and undesirable ones, may expend much time, effort and money in excavating, packing, and shipping specimens of little value. It may be mentioned here that juniper, as wood or charcoal, is less subject to deterioration than pinyon or pine. A field man who is not a dendrochronologist may have carefully collected what he believes to be enough wood to ensure him a range of dates, yet easily have overlooked specimens which might well be those he needed. It is the friable piece of pinyon lying next to a more solid piece of juniper that is important. This does not mean that good looking, whole specimens are to be ignored; pinyon is sometimes found in good condition. By efficient excavation of charcoal "on a dig" a dendrochronologist can save a great deal of time and expense, and also ensure the removal of the maximum in datable pieces.

From the viewpoint of the laboratory worker, the waste represented in collecting large lots of juniper is also excessive; too much time is consumed in weeding out this material. In one case the few fragments of pinyon or pine included were not enough to assign a date; this crippled the ensuing publication. The mere presence of any datable material implied, however, that there had been more. As it was, time had been wasted both in the field and laboratory and no results were obtained.

The writer has had occasion to prove this point in excavating a burned site in which 95% of the construction was juniper, a few good specimens of which were saved. Positions of beams were noted and, when juniper, little time was expended in their removal. The few pieces of pinyon were carefully uncovered and wrapped immediately for shipment. Despite scarcity of pinyon, this site was readily dated. No time was wasted in removing or packing worthless material, yet all datable wood was secured. The time saved in the laboratory was also notable.

Processes in the actual excavation of tree-ring material vary with each worker. While one method may be more successful than another, the main thing is to get the specimen out intact. Hired laborers or volunteer workers, not appreciating the significance of the piece of wood under excavation may not take adequate precautions. This is a point impossible to overemphasize. The writer has seen workers who should have known better, hacking away at a piece of charcoal. If the removal of wood and charcoal specimens is entrusted to a competent dendrochronologist, this destruction will be prevented. The expense saved in using untrained workers for excavation of tree-ring material will not compensate for the dates lost, or for the extra time expended in the laboratory upon damaged specimens. The director of a field expedition who insists upon the presence of a dendrochronologist may leave this phase of the work to the specialist, knowing that no possibilities in securing dates will be overlooked or lost.

Various methods of packing charcoal have been used, most of them satisfactory, but often costly. Many hours have been spent in the laboratory prying away cotton stuck to specimens too heavily impregnated with paraffin. A more judicious use of paraffin is advisable, in that it may not always be necessary. The condition of the specimen should determine how it is to be packed. Specimens have been shipped in large boxes just as they came from the ground, without wrapping. The trip to the depot over rough roads had reduced the more friable specimens to dust; the larger ones had all of the original surface ground away. There is little to commend about this method. It is the equivalent of packing a dozen skeletons in one large container and, after shaking well, sending them on a long journey to an osteologist who would be expected to reconstruct each skeleton for study. A dendrochronologist knows how a specimen should be packed. If it is a long beam, he knows how much of it to pack, and he can be sure that when he has packed a piece of wood or charcoal, it will arrive at the laboratory in the same condition it left the ground. Without proper packing, all previous precautions are wasted.

Labelling specimens has become a habit with most field workers and is a practice with which all are familiar. A dendrochronologist on an excavation will label different fragments of one beam so that they will be identified with one another. Each fragment of a given beam should be so recorded, although it may be separately wrapped. In this manner the identity of each beam is clear and duplicate dating of the same timber is avoided. The unnecessary dating of many fragments of the same specimen means hours of tedious and costly work in the laboratory. For example, in a case where specimens were properly excavated, packed and labelled, a large amount of charcoal was dated in shorter time than usual, since there was little duplication in dating. The assignment of a construction date was possible, due to carefully preserved beam exteriors; a provisional date of abandonment was possible since small branches which had retained exterior surfaces were obtained from the fire-pit.

The advantages of having a dendrochronologist present in the field are, briefly:

1. Assurance of retrieving the maximum amount of datable material.
2. Greater accuracy in dating.
3. Proper handling of specimens at all times.
4. Time and expense saved during excavation by eliminating time and cost in indiscriminate collecting.
5. Time and expense saved at the laboratory by eliminating undesirable and improperly packed specimens.
7. Saving in packing and shipping costs by making a more desirable and less bulky collection than could be made by a non-selective worker.
8. Any dendrochronologist actively engaged in dating is a trained archaeologist as well, and so can assist in excavation when not occupied in his own special field.
9. Because of his knowledge of the region in which the trees grew, the dendrochronologist is enabled to give additional evidence concerning the ecology of the area in prehistoric times.

The service performed by dendrochronology for archaeology will become immeasurably greater if archaeologists themselves realize more generally that dating is not accomplished entirely within the laboratory. Results obtained depend largely upon methods employed in the field.

The writer is indebted to Lyndon L. Hargrave for constructive suggestions and comment.

E. T. Hall, Jr.  
Santa Fe, New Mexico

March, 1939

Footnotes:

1. Secrets of the Southwest Solved by Talkative Tree Rings, by A. E. Douglass, National Geographic Magazine, Vol. 56, pp.736-770, 1929.
2. University of Arizona, Tucson; Museum of Northern Arizona, Flagstaff; Gila Pueblo, Globe, Arizona; Laboratory of Anthropology, Santa Fe, New Mexico; University of New Mexico, Albuquerque.
3. The Field Collector of Beam Material, by Lyndon L. Hargrave, Tree Ring Bulletin, Vol. II, No. 3, pp. 22-24, January 1936.

\* \* \* \* \*

A Tree Ring Bibliography  
Submitted by Gertrude Hill, Flagstaff,  
Arizona

General

"Award of the Prize of the Research Corporation." *Science*, n.s., v. 74,  
pp. 237-238, Sept., 1931.

Bryan, B.

Reading History from the Diary of the Trees. *American Forests*,  
v. 40, pp. 10-14, January, 1934.

Carnegie Institution of Washington

Annual Report of the Chairman of the Division of Plant Biology,  
Year Book No. 33, 1933-34.

"Dendroheliometer Used for Measuring Tree Rings." *Scientific American*,  
v. 156, p. 112, February, 1937.

"The Development of Dendrology." *El Palacio*, v. 31, No. 13, pp. 196-198,  
September 30, 1931.

Douglass, Andrew Ellicott

Conclusions from Tree-ring Data. *Geographical Review Supplement*,  
v. 13, pp. 659-661, Oct., 1923.

Douglass, Andrew Ellicott

Tree Rings and Chronology. *University of Arizona Bulletin*, v. VIII,  
no. 4, 1937; *Physical Science Bulletin* no. 1.

Glock, Waldo Sumner

1934. Language of Tree Rings. *Scientific Monthly*, v. 38, pp. 501-  
510, June.

1937. Principles and Methods of Tree-ring Analysis. Publication  
No. 486, Carnegie Institution of Washington.

1933. Tree Ring Analysis on the Douglass System. *Pan American  
Geologist*, v. 60, pp. 1-14, August.

"Growth-rings of a Tree." *Literary Digest*, v. 96, pp. 21-22, January 21,  
1928.

Hough, A. F.

Method of Preparing Wood Sections for Accurate Age Counts.  
*Journal of Forestry*, v. 33, p. 698, July, 1935.

McGregor, John C.

Tree Ring Dating. *Museum Notes*, v. 3, no. 4, October, 1930.



Moorehead, Warren K.

Forgotten Tree Ring Record. Science n.s., v.80, p. 16, July 6, 1934

"Research Corporation Awards to A. E. Douglass and Ernst Antevs for Researches in Chronology." (In Smithsonian Institution. Annual Report, 1931. Washington, Government Printing Office, 1932. pp. 303-324).

Tree Ring Bulletin. Tree Ring Society, 1934 - date. Published quarterly.

### Archaeology

Antevs, Ernst

Dating Records of Early Man in the Southwest. (In Early Man in America, with Particular Reference to the Southwestern United States; a Symposium. American Naturalist, v. 70, pp. 313- , July-August, 1936).

Boone, A. R.

Twelve Centuries of American History Revealed by Ancient Trees. Popular Science, v. 119, pp. 16-17. September, 1931.

"Dating Old America." Literary Digest, v. 121, p. 29. April 11, 1936.

"Dating Pueblo Ruins." The Masterkey, v. 10, no.3, p. 112. May, 1936.

Davis, E. C.

Tree Rings and the Mayan Calendar. Science n.s., v. 36, p. 10, Supplement, November 26, 1937.

Douglass, Andrew Ellicott

La Chronologie des Pueblos. Revue Archaeologique, Paris, 1931.

Douglass, Andrew Ellicott

Dating Our Prehistoric Pueblo Ruins. (In Smithsonian Institution. Explorations and Field-work, 1929. Washington, Government Printing Office, pp. 167-176. 1930

Douglass, Andrew Ellicott

Dating Our Prehistoric Ruins. Natural History, v. 21, pp. 27-30 January, 1921.

Douglass, Andrew Ellicott

Dating Pueblo Bonito and Other Ruins of the Southwest. National Geographic Society, 1935. (Contributed Technical Papers. Pueblo Bonito Series no. 1)

Douglass, Andrew Ellicott

The Secret of the Southwest Solved by Talkative Tree Rings.

National Geographic Magazine, v. 56, pp. 736-770, December, 1929.

Tree Rings and Dating of Southwestern Prehistoric Ruins. American Society of Civil Engineers, San Francisco Section, Proceedings, 158th Meeting, August, 1931.

Franke, Paul R.

New Dates from Mesa Verde Ruins. Mesa Verde Notes, v. 4, no.1, pp. 19-20, July, 1933.

Haury, Emil W. and Hargrave, L. L.

Recently Dated Pueblo Ruins in Arizona. Smithsonian Miscellaneous Collections, v. 82, no. 11, Washington, 1931.

Haury, Emil W.

Tree Rings - the Archaeologist's Time-piece. American Antiquity, v. 1, no. 2, pp. 98-103, October, 1935.

Hawley, Florence M.

The Significance of the Dated Prehistory of Chetro Ketl, Chaco Canyon, New Mexico. University of New Mexico Bulletin, Monograph Series, v. 1, no. 1, Albuquerque, 1934.

Judd, Neil M.

Dating our Prehistoric Pueblo Ruins. In Smithsonian Institution, Explorations and Field-work, 1929. Washington, 1930.

Pueblo Bonito, the Ancient. National Geographic Magazine, v. 44, pp. 99-103, July, 1923.

McGregor, John C.

Additional Prehistoric Dates from Arizona. Museum Notes, v. 5, no.3, September, 1932.

Morris, Earl H.

Exploring in the Canyon of Death. National Geographic Magazine, v.43, no. 3, pp. 263-300, September, 1925.

"Oldest Tree Ring Record of Ancient Pueblos." El Palacio, v. 32, no.7-8. pp.108-110.

Stallings, William S., Jr.

A Tree-ring Chronology for the Rio Grande Drainage in Northern New Mexico. Proceedings, National Academy of Sciences, v. 19, no. 9, pp. 303-305, September, 1933.

"Tree-rings Date Indian Ruins." Literary Digest, v.104, p. 29, Feb.,1930.

"Tree Rings to Date Diseases that Plagued Prehistoric Americans of the Southwest." Science, n.s., v.81, Supplement, p. 6, March 8,1935.

Wissler, Clark

Dating our Prehistoric Ruins. Natural History, v.21,no.1, pp.13-26, 1921.

Astronomy: Sun, Sunspots, Solar Radiation

Duncan, John Charles

Astronomy. 2nd ed. rev. Harper Brothers, 1930.

Russell, Henry Norris and others

Astronomy. 2 vol. Ginn and Company, 1926-27.

Botany

Record, Samuel James

Identification of the Timbers of Temperate North America.  
John Wiley, 1934.

Cycles and Climate

"Cycles in Natural Phenomena." Nature, v. 125, pp.18-19, Jan.4, 1930.

Douglass, Andrew Ellicott

Climatic Cycles and Tree Growth. 2 v. Carnegie Institution of Washington, Publication no. 289, 1919-1928.

Evidence of Climatic Effects in Annual Rings of Trees. Ecology, v. 1, no. 1, pp. 24-32, January, 1920.

Evidences of Cycles in Tree Ring Records. Proceedings, National Academy of Sciences, v. 19, pp. 350-360, March, 1933.

Past Changes in Climate in Relation to Settlements in the New World. Pan American Geologist, v. 54, p. 318, November,1930.

Solar Records in Tree Growth. Science, n.s., v.65, pp. 220-221, March 4, 1927.

Some Aspects of the Use of Annual Rings of Trees in Climatic Study. Scientific Monthly, v. 15, no. 1, pp. 1-22, July,1922

Some Aspects of the Use of Annual Rings of Trees in Climatic Study. In Annual Report for 1922, Smithsonian Institution, pp. 223-239, Washington, 1923.

Douglass, Andrew Ellicott

Some Topographic and Climatic Characters in the Annual Rings of the Yellow Pines and Sequoias of the Southwest. Proceedings, American Philosophical Society, v. 61, pp. 117-122, 1922.

Tree Growth and Climatic Cycles. Scientific Monthly, v. 37, pp. 481-495, December, 1933.

Tree Rings and Climate. Ibid., v. 21, pp. 95-99, July, 1925.

Tree Rings and their Relations to Solar Variations and Chronology. In, Annual Report for 1931, Smithsonian Institution, pp. 304-312, Washington, 1932.

Weather Cycles in the Growth of Big Trees. Monthly Weather Review, June, 1909.

Jaffe, Bernard

Outposts of Science. Simon and Schuster, 1935. (pp. 473-475)

"Tree Rings and Weather Cycles." Science n.s., v. 60, Supplement, p. 10, December 26, 1924.

#### Ecology

McDougall, Walter Byron

Plant Ecology. (2nd Ed. rev.) Lea and Febiger, 1931.

Shreve, Forrest

The Vegetation of a Desert Mountain Range as Conditioned by Climatic Factors. Carnegie Institution of Washington, 1915.

#### Geology, Paleontology, and Paleobotany:

Petrified Wood, Varves, Pollen

Antevs, Ernst

Climatological Significance of Annual Rings in Petrified Woods. American Journal of Science, 5th Series, v. 9, pp. 296-302, April, 1925.

Retreat of the Last Ice Sheet in Eastern Canada. In Canada, Department of Mines, Geological Survey Memoir 146, no. 120.

Bryan, Kirk

The Papago Country, Arizona. U.S. Geological Survey, Water-supply Paper 499, Washington, 1925.

Gregory, Herbert E.

The Navaho Country. U.S. Geological Survey, Water-supply Paper 380,  
Washington, 1916.

Knowlton, Frank Hall

Catalogue of the Cretaceous and Tertiary Plants of North America.  
U.S. Geological Survey, Washington, 1898.

Catalogue of the Mesozoic and Cenozoic Plants of North America.  
Ibid., Bulletin 696, Washington, 1919.

Evolution of Geological Climates. Geological Society of America,  
Bulletin, v. 30, pp. 499-565, December 30, 1919.

Sears, Paul Egelow

The Archaeology of Environment in Eastern North America. American  
Anthropologist, v. 34, pp. 610-622, October, 1932.

#### Meteorology

Abbott, Charles G.

Sun Spots and Weather. Smithsonian Institution, Miscellaneous  
Collections, v. 87, no. 18, 1932-34, Washington, 1935.

Clayton, Henry Helm

World Weather and Solar Activity. Smithsonian Institution,  
Miscellaneous Collections, v. 89, no. 15, Washington, 1934.

Douglass, Andrew Ellicott

Method of Estimating Rainfall by the Growth of Trees. In Huntington,  
Ellsworth. The Climatic Factor as Illustrated in Arid America.  
Carnegie Institution of Washington, Publication no. 192, 1914.

"Rings of Trees to Solve Weather Mysteries." Popular Mechanics, v. 50,  
pp. 48-49, July, 1928.

Comments Concerning Certain Mineralogical Terminology

In the March 15th issue of the NOTEBOOK I noted the comment of Mr. P. Schuyler Miller of Scotia, New York (p. 16) where he requested information concerning the meaning of various rock and mineral terms. Though a complete discussion of the quartz family could not be undertaken in a "note" I should be pleased to offer certain interpretations based upon a mineralogist's point of view. To restate Miller's query for the sake of continuity, it is as follows: "What do various workers - including geologists - mean when they speak of flint, chert, hornstone, jasper, argillite, chalcedony, rhyolite, or obsidian? What defines one material from the other?"

To begin with, this list includes both minerals (homogeneous chemical compounds) and rocks (usually more complex). Rhyolite, obsidian and argillite are the names of rocks of complex chemical composition. The others are terms assigned to various members of the quartz family of minerals or to rocks chiefly composed of such minerals. Let us consider these first. Quartz appears naturally in three modifications; i.e., the chemical compound silicon dioxide ( $\text{SiO}_2$ ) may be either crystalline, cryptocrystalline or amorphous. There are the following crystalline varieties: rock crystal, amethyst, rose-quartz, smoky-quartz, citrine, milky-quartz, cat's eye, and tiger's eye as well as others, some of which contain numerous inclusions of other minerals. Rough (uncut and unpolished) mineralogical specimens of crystalline quartz are readily identifiable as such by their vitreous appearance, hardness of 7, specific gravity of approximately 2.65-2.66, and typical conchoidal fracture.

Most of the quartz specimens which were useful to prehistoric man are of the cryptocrystalline varieties. Cryptocrystalline means that to the unaided eye the material shows no apparent characteristic shape, or obvious crystalline arrangement. However, a crystalline structure is indicated microscopically, for such materials effect the passage of light in the same manner as crystalline substances. The physical and optical properties of cryptocrystalline quartz are inferior to those of the crystalline variety. The term chalcedony may be used to cover all such quartz specimens. Under this all-inclusive name are found the sub-varieties known and described as follows:

1. Carnelian - Red chalcedony, often of gem quality.
2. Chrysoprase - Apple green variety, often of gem quality.
3. Prase - Leek green, often of gem quality.
4. Heliotrope or Blood-stone - Green with red spots, (hematite inclusions), often of gem quality.
5. Agate - Variegated chalcedony, parallel bands of coloring, sometimes concentric bands, often gem quality. Colors may be irregular.
6. Onyx - Banded, like agate, except that bands are in straight line; often of gem quality.

7. Flint - Something like chalcedony but dull, dark colored, dark-gray or black, fine-grained homogeneous appearance.
8. Jasper - Opaque, colored red (by hematite). Colors may be reddish-brown, very dull dark greens or grayish blue. Certain yellowish to brownish jaspers have been called Egyptian Jasper.
9. Hornstone - An impure horny looking jasper, generally opaque and grayish to brownish, luster dull.

Chert is a name applied by geologists to light-colored rocks which are made up of minutely-grained silica. These rocks are commonly white, gray, or blue-gray. Flint is the dark gray or black variety of this rock which commonly occurs as nodules in chalk (a variety of limestone). Chert (or flint) may be chalcedony (cryptocrystalline quartz) alone or an intimate mixture of extremely fine-grained quartz (crystalline) and chalcedony. Thus one speaks of a geological formation of chert which upon mineralogical analysis is found to be composed of quartz or chalcedony or both of these silica minerals. A recent report upon the terminology of the siliceous sediments suggests the desirability of abandoning the word flint as a rock name in favor of chert.\*

The following comparison may aid in understanding the usage of the terms chert and chalcedony. Chert is applied to cryptocrystalline silica rocks just as the word limestone is employed to designate formations of calcium carbonate. Pure limestone is composed entirely of the mineral calcite (or the rarer aragonite). Similarly, chert is composed of the mineral quartz (or chalcedony), which may be present in the varieties previously listed.

From the foregoing it would appear that the mineralogical distinctions between the various chalcedonies are color differences, and unfortunately much ambiguity exists because of improper usage of names without consideration of the approved designations.

The third variety of the quartz family minerals, namely the amorphous silica, commonly known as opal, is of minor archaeological importance. In general it may be defined as a mineral-gel, being composed of  $\text{SiO}_2$  and a varying amount of water. It is usually employed as an ornamental stone or in jewelry. Specimens of opal are identifiable by their inferior hardness to quartz and their low specific gravity: H. 5.5 - 6.5; G. 1.9 - 2.3. Luster vitreous to waxy (or resinous). Color varieties: colorless, white, pale shades of pink, yellow, red-brown, green, gray and blue with or without a fine play of colors. Transparent to opaque.

---

\* Report of The Committee on Sedimentation, 1937-38. Parker D. Trask, Chairman. National Research Council, Washington, D. C. page 26.

Turning from the quartz family minerals to the three remaining terms in Miller's note we find that they are names for rocks. Rocks are names (1) according to their composition and (2) according to their texture, or shall we say appearance. Rhyolite and obsidian are rocks of igneous origin as are the coarsely grained compositional equivalent granites. Igneous rocks are classified into three major groups:

I. Phanerites (grained rocks, grains visible megascopically). These are intrusives.

II. Aphanites (individual grains, except phenocrysts, unrecognizable megascopically). These are extrusive or intrusive close to the earth's surface.

III. Glassy rocks (composed wholly or largely of glass). These are extrusive rocks. A porphyry is a rock composed of numerous crystals sometimes rather well-defined, sometimes more or less eaten away by redissolving in the residual groundmass. The crystals represent an early stage of mineral separation and the aphanitic (indistinguishable) groundmass represents the residual liquid mass which cooled rapidly during its solidification and thus did not produce visible crystals. Compositionally a rock containing quartz and orthoclase feldspar and having well defined visible grains is said to be a granite. If the rock is porphyritic and the phenocrysts are quartz and orthoclase or plagioclase feldspar it is a felsite. On the other hand, if the same rock was formed extrusively by such rapid cooling that even an exceedingly fine-grained groundmass was unable to be produced, the rock would have a glassy appearance and would be obsidian. This we see that compositionally there is little or no difference between a granite, rhyolite or an obsidian. The difference is a textural classification rather than a chemical one. Those wishing more information on the subject of rock terminology are referred to the various excellent texts on the subject, i.e., Rocks and Rock Minerals by Pirsson and Knopf, John Wiley and Sons; The Principles of Petrology, Tyrrell, E.P. Dutton and Co., are two of good repute.

Obsidian includes three varieties in addition to the usual vitreous types:

- Pitchstone - Resinous, pitch-like in appearance, vari-colored, black less common.
- Perlite - Glassy rock with perlitic structure produced by small spheroidal fractures, usually gray.
- Pumice - Highly vesicular glass, white or light colored.

Obsidian has a strong vitreous, bright glassy luster, is usually black, red, red-brown, greenish or grayish. It has been said that obsidian is a granite which never had a chance to form. It is a typical extrusive igneous rock and is commonly found in volcanic regions.



An argillite is best defined as a hard, indurated shale, without fissility or cleavage (Pirsson and Knopf, p. 342). The induration (hardening) is explained as the result of dehydration and crystallization of the constituents originally present in the shale or clay. Many indurated shales are difficult to distinguish in the field from cherts and felsites. Microscopically or chemically they are separable and their clay origin is obvious.

David H. Howell  
Claremont, California

\* \* \* \* \*

### A Card Filing System for Notes and Abstracts

By H. M. Wormington  
Denver, Colorado

In recent issues of The Notebook a great deal of attention has been devoted to the extremely important question of the assembling of anthropological libraries. While the possession of a library is highly desirable, a sound knowledge of the information contained in the books which compose it is even more important. In the case of scientific literature a cursory reading is not normally sufficient and sooner or later the student must face the problem of taking notes upon what he has read. The taking of notes is essential for a number of reasons. The organizing and condensing of material serves to fix it more firmly in the mind of the reader. When information is needed at some later time it may often be obtained without searching through numerous publications. Page references make it possible to check back to the source material whenever necessary. Data from publications which are not always available are preserved for future use.

If the taking of notes is approached in too casual a manner, however, it often serves no real purpose. The student may find himself possessed of an assortment of notes with no unity of form, scribbled on stray pieces of paper. When reference must be made to notes gleaned from some specific publication or dealing with some particular subject, he is faced with a difficult task. If a great deal of reading is done the use of some sort of system becomes imperative.

A good system should be more or less standardized yet readily adaptable to the changing needs of the individual. It should preserve notes in a permanent form, should make it possible to find any given data with ease and rapidity, and should be sufficiently simple that the problem of organization does not become a burden.

A number of systems fulfill these requirements and the selection of any particular type is largely a matter of personal inclination. The one now in use in the Department of Archaeology of the Colorado Museum of Natural History has proved extremely satisfactory in every way, however, and a brief description may be of value to others. There are, of course, no hard and fast rules, and these are simply suggestions. The system is sufficiently flexible that it may be easily varied to conform to individual needs.

Notes are made on plain or ruled 5" x 8" cards. This has proved to be a convenient size. These cards may be used satisfactorily for field and lecture notes as well as reading notes and are large enough for sketch maps, drawings, etc. Newspaper articles dealing with anthropological subjects may be cut out and glued to cards which may then be catalogued and filed.

A bibliographical card is made for each reference upon which notes are taken, as well as for publications which have not yet been read but which it is thought desirable to record for future consultation. In the upper right hand corner is written the word "Bibliography" and directly below it the name of the subject covered by the publication. A notation in the upper left hand corner indicates whether notes have been taken, the number of cards used, and the letter or heading under which they have been filed. Below is listed all necessary bibliographical information, name of the author, name of the publication, where published and by whom, number of plates and figures, data, etc., and a brief resume of the material covered.

Example:

6-B	BIBLIOGRAPHY Basketmakers
<p>Amsden, Charles Avery - The Ancient Basketmakers -  The Masterkey, Southwest Museum, Los Angeles,  Vol. XII, No. 6, Nov., 1938. pp. 205-214,  4 figs., 1 map.</p>	
<p>First in a series of articles. Covers habitations, dress, ornaments, hairdressing, physical types, dogs. Treats Basketmaker as a whole, not by periods. Excellent general summary; more or less popular.</p>	

When notes are taken on a reference, the name of the subject covered is placed in the upper right hand corner, the last name of the author and the year in which the publication appeared is placed in the upper left hand corner; the notes are placed below. If a number of cards are needed to cover the same general subject, further subdivisions may be made directly below the main title or the card may be numbered serially.

Example:

Amsden - 1938	<u>Basketmakers</u> <u>Physical Type</u>
<p>Racial Affiliations: Indians  Head Form: Mainly dolichocephalic, medium height, moderately rounded crown  Face: Medium length  Stature: Short. Men little over 5 feet, women less  Body Build: Moderately sturdy, somewhat like present Pueblo  Hair: Mongoloid (straight, coarse, black). Children finer  Body Hair: Sparse. Mongoloid trait  Skin: Medium to dark brown. Children lighter.</p>	

If it can be accomplished without making the work of organization too arduous, it is best to standardize subheadings wherever possible. For example, if a list of physical attributes be placed in the same order on all cards dealing with physical type it will greatly facilitate obtaining comparative data.

All cards are filed in expanding envelopes containing index cards. The envelope which has proved most satisfactory is "Favorite" Steel Sealed Expanding Envelope No. 8-2 C.G. Size 5 $\frac{1}{2}$  x 8  $\frac{3}{4}$  made by the Cooke and Cobb Co.

Index cards may bear printed headings or may be alphabetical. One section should be reserved for bibliography. Most alphabetical series contain one index card headed Mc. This may be reversed and the word "Bibliography" printed on the other side. Filing of notes may be done on the basis of geographical or chronological position, or in accordance with any other system which seems desirable. For instance, the sample card shown above might also be filed under Southwest, Archaeology, Physical Types, or a variety of other headings, depending on the manner in which the file as a whole is to be organized.

At first it is usually sufficient to have a single envelope in which all notes are kept. Later, as it becomes too full, it is best to begin another file where all notes relating to some specific subject may be kept. For example, after a general anthropological file became too bulky, a new one might be begun which would contain only notes on Southwestern Archaeology. As this in turn became filled it might be divided into more than one envelope, one being reserved for the oldest complexes, Folsom, Yuma, and others; another for Basketmaker and Pueblo, a third for Hohokam, etc.

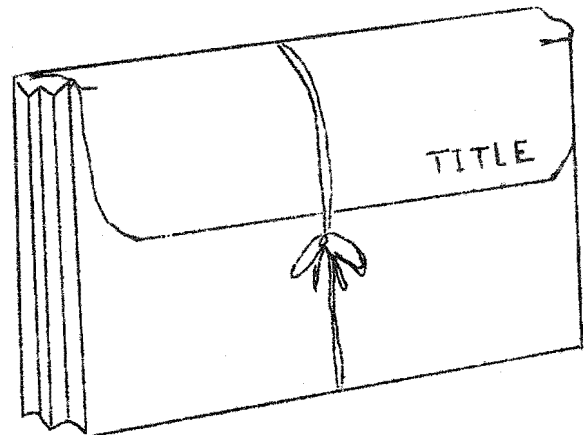
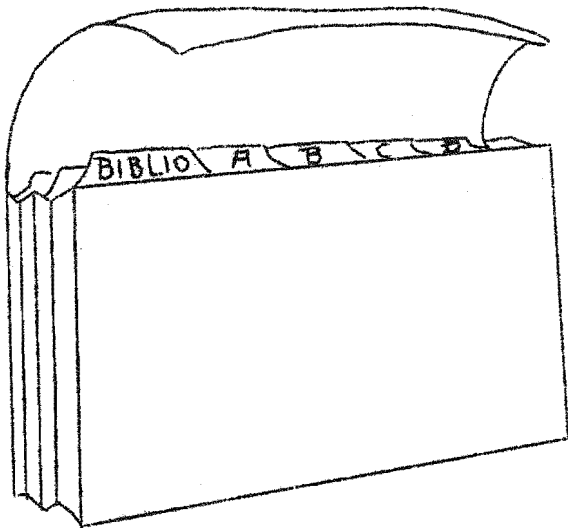

The system must of necessity vary with the needs and interests of the individual. Organization, however, is essential. If properly handled, it should take little more time to follow an intelligent system than would preparing notes in the most haphazard manner. The ease with which information can be found whenever needed will soon show how well worth while it is.

\* \* \* \* \*

NOTICE

No pages of The Notebook will be issued during the summer months; that is, in the interval between the July and October issues of AMERICAN ANTIQUITY. The next group of pages for The Notebook will be distributed about the middle of November. However, letters and manuscripts for The Notebook may be sent to the office of the Secretary-Treasurer at any time during the summer.

LETTERS

Dear Editor:

Why not reserve one page in the Notebook for photographs? There are numerous excellent prints in the files of archaeologists which would be interesting and instructive. Many of these could be used to advantage if their publication is under the discretion of the editor. The actual prints could be adhered to the Notebook sheets.

April 8, 1939

Roy Latham  
Orient, Long Island, N.Y.

(Editor's note: The use of actual prints in an edition of 1000 is out of the question. Yet photographs may be reproduced by lithoprinting process on an  $8\frac{1}{2}$  x 11 sheet for about \$15.00 a thousand, if the demand for such a service seems sufficiently great.)

\* \* \* \* \*

Dear Editor:

The metric system has aptly been referred to as the "acme of simplicity." Its value lies in the ease of reduction by tens and multiples of ten. Most physical and biological sciences adhere to this highly efficient method of stating size, position, or quantity of objects discussed. A perusal of the literature shows that many writers of archaeological discourses express themselves in a system that is rapidly becoming antiquated as a tool of science.

Since the metric system is used almost universally by the scientist, we should keep abreast with our fellow workers and follow the lead of those few who do recognize the importance of the system, and adopt it in its entirety. Field and laboratory equipment would have to be altered to conform with other revisions. Yet the effort expended will be more than compensated for in results obtained.

March 22, 1939

H. R. Aantle  
Sulphur, Oklahoma

\* \* \* \* \*

Dear Editor:

Regarding the use of India ink as a marking medium, the objection to its use is overcome if the numbers and letters are placed on the prepared base. Personally I prefer a dab of shellac to the use of a cellulose mixture. After the shellac has dried and the number has been applied, a second dab is brushed over the symbol thus sealing the number between two waterproof coats. We have tried the cellulose mixtures and when applied to porous material, or on smooth surfaces, in time the material has a tendency to contract and peel the number (and part of the specimen) off. Moreover, a cellulose mixture cannot be used successfully upon any material that is either slightly damp or contains grease. The adhesive will whiten and curl up. Shellac, orange or white, will adhere better in the long run. To remove, one simply uses a bit of alcohol. The new pigment inks on the market which range in a variety of opaque brilliant colors are excellent for marking, providing one shakes well before using; they can be applied with either fine brush or pen. We generally use white or yellow inks for dark specimens, and black ink for light specimens.

Another stunt in marking specimens, particularly in a large collection, is to place a dot of green, red, or any other color different from the color used in making the numbers, after an identifying specimen number, if the object has been photographed. There are times when extra photographs are wanted by outsiders and to avoid repetition and having the same specimen re-photographed, this simple system tells at a glance whether that particular item has been photographed.

Concerning the use of ambroid or other cellulose mixtures as preservatives to be used on rotten wood, bone, shell, charcoal, etc., the important thing to be remembered is to dilute the ambroid with acetone to almost water thinness. Unless this is done, the ambroid will not penetrate the object thoroughly and so defeat the purpose. Small objects such as shell beads, bone awls, etc., can be placed in a bath of this solution and allowed to remain there until all bubbles cease to rise. If the solution is thin enough, the specimen will be strengthened and yet will not have the glossy surface which renders shellac so objectionable for this purpose. A successful treatment

should leave the surface coloration practically unchanged. It must be added, however, that liquid clear ambroid, not the amber-colored stuff, should be used when preservation is the goal. The important rule is **KEEP THE MIXTURE THIN**. Enough ambroid should be added to the acetone, and thoroughly dissolved so that when a drop or two is taken between the thumb and forefinger that it dries with just a slight tackiness, not enough to be sticky but enough to tell by the feel that the cement is in the solution. Too much ambroid will spoil the effect.

If shell or bone or pottery coated with lime deposit is first washed in a solution of hydrochloric acid and water, then rinsed thoroughly in running water and well dried, then immersed in ambroid bath, the specimen will appear as good as new. In the case of shell, the iridescent surface will not become encrusted with lime again. I have some 800 abalone shell pendants which were thus treated in 1932, and they are as bright and clear as the day they were made; yet when we found them, they were chalk white. Speed in passing the objects through a 50-50 solution of acid and water is essential in cleaning small objects. We use a small strainer, place a quantity of the beads or pendants therein, and swish it through the acid. The stuff hisses and boils; a scum appears on the surface; we draw the strainer out and thrust it under running water until all the acid is washed away. After drying, the pendants are placed in the ambroid bath, removed and dried on a bit of screen or strung on a wire. If the mixture is thin enough, the specimens will not adhere to the screen; otherwise, they will be glued fast. Hence, use the acid bath speedily, keep the ambroid bath thin, and there will be no trouble.

Arthur Woodward  
Los Angeles Museum of History,  
Science, and Art  
Los Angeles, California

March 31, 1939

\* \* \* \* \*

#### ARTIFICIAL STONE AS A RESTORATION MATERIAL

By P. F. Titterington  
St. Louis, Missouri

Artificial stone is a combination of cement and plaster of Paris used by dentists in the making of models for their crown and plate work. It has been found that it also can be used to good advantage in repairing certain objects in the archaeological laboratory.

It has served its best purpose in our hands in repairing skulls in which a small portion of bone is missing. A piece of modeling clay is inserted through the foramen magnum, and held in place by a stick also inserted through the foramen magnum. The clay is moulded so that the

edges of the bone are exposed, and so that the under surface of the repair will be flush with the inner surface of the skull. The plaster is applied over the area to be refilled, in excess, and allowed to set for a few minutes. The excess is then shaved away with a sharp knife until the shape of the repair is made to conform to that of the missing portion of the bone. This can be done before the plaster sets to its stony hardness. The modeling clay is then removed from the inside of the skull.

If the missing parts of the skull are too long and narrow, or otherwise large to be backed with modeling clay, several thicknesses of newspaper can be rolled up and inserted through the foramen magnum and held against the opening with a stick, as described above. The rest of the procedure is the same as previously described.

Small areas in pottery can be restored by the modeling-clay method. Moreover, when a lug or a handle, with or without the associated portion of the rim, is missing, it can be restored by making, in a piece of modeling clay, an impression of one of the lugs or handles that is present. This mold is then placed on the outer surface of the pot, exactly where the part is missing, and filled with plaster. After the plaster has set for a few minutes, the mold is removed and the plaster handle trimmed before it becomes too hard. If small pieces of the repair should break away at the point of contact with the pot, these places can be filled in with fresh plaster.

The artificial stone is white or yellowish in color. Various shades of gray or black can be produced by thoroughly mixing the plaster with lamp black before the water is added. The more of the lamp black used, the darker the gray. Equal volumes of lamp black and plaster produce almost a black color. No attempt has been made to produce other colors.

The repair of stone artifacts has been attempted only a few times. The process as described is satisfactory for the larger and heavier pieces, but is not so satisfactory for the thin flint pieces. Our method has been to take a flat piece of modeling clay and to press the flint piece firmly into one surface. The clay in the area to be restored is removed and a mold shaped so that the blank for the repair will be somewhat thicker than when finished. Care must be taken to make a good contact between the flint and the repair, because the plaster will not adhere to the flint. After the repair is shaped it will have to be fastened in place with ambroid. The plaster must be completely set before the trimming and shaping are started, because if it is not, the edges of the repair will crumble. After the plaster has completely set, it is so hard that it is very difficult to trim and shape, and the thin edges still have a tendency to break on account of being brittle.



Artificial stone has proved to be a satisfactory material for restorations when the shaping can be done before the plaster sets to its stony hardness. This can be done to the best advantage when the surface of the repair is flush with the surface of the object being repaired, such as skulls. It is also a satisfactory material for repairing pottery, even in building in a portion of a rim. The rim is sufficiently thick to permit the repair to be shaped properly without a great deal of effort or breakage. This material is not practical for repairing flint pieces when a thin edge is necessary, because of the chipping and breaking of the thin edge.

\* \* \* \* \*

March 15, 1939

POTTERY RESTORATION AT THE MILWAUKEE PUBLIC  
MUSEUM

By Eldon G. Wolff, Milwaukee  
Public Museum

In the past a great variety of methods and materials have been employed in the repair and restoration of pottery, with almost as great a variety in results. In the attempt to produce a satisfactory restoration, the writer and his associates have experimented with numerous processes and ultimately arrived at one which has met all essential requirements.

This method, while seemingly a complicated technique, is in reality sufficiently simple for an individual with average manual dexterity to employ with satisfactory results. Another agreeable feature is the fact that the vessel subsequently may be re-restored at a future date if the original restoration is not correct or if the technician's skill has advanced to the point where he would like to do the work over in a better fashion.

Repairing

Before one begins with the preparation of the sherds, it is necessary to decide whether a restoration is the end or whether the original material should be available subsequently for chemical or physical analysis. Inasmuch as the sherds are greatly strengthened by sizing with a hardening agent, this is recommended as the first step in repairing. Certain individuals feel that such a sizing renders the sherds unfit for

analysis. It must be decided, therefore, which purpose is of greater importance. In this instance, repair and restoration are considered primary.

Except in the instance of certain varieties of painted or slip ware, pottery will stand careful washing with water. This is necessary to remove adhering earth, sand, or other foreign material. In the case of very friable ware, acetone may be employed for washing. After thorough drying, the sherds are immersed in a very thin solution of celluloid cement and C.P. Acetone, the commercial brands "Ambroid" and "Zapon" being well suited to the purpose. The colorless grades should be demanded of the dealer. Immersion should be continued until all bubbling of air ceases, after which the sherds are drained and allowed to dry normally. Depending upon the concentration of cement in the sizing solution, more or less will remain in the sherd, strengthening it materially and preventing the crumbling, so common in stone-tempered wares, or the flaking characteristic of some varieties.

The next step is the assembling of the pieces into large sections, which in turn are later united into the complete pot, or that portion of it available. No special instructions can be given regarding the finding of joints. This part of the repairing is a matter of experience, and also of luck. The greatest requisite is patience and application. It is advisable, however, when a joint is found, to mark it on the reverse side with a colored crayon, lest the fit be lost while cement is applied to one or the other surface preparatory to joining.

The cement is applied, full strength, by means of a brush, to both surfaces of the joint, after which they are fitted together snugly and the excess cement which exudes is smeared along the line of union. This cement does no damage and is recommended for the inner surface of the vessel. If that which is present on the outer surface is objectionable, it may be rubbed off lightly while still wet, and later, after the rest has dried, may be removed by brushing with acetone. The primary objection to this cement on the outer surface is the fact that it makes the surface to which it adheres glossy.

After joining several fragments, the unified piece may be allowed to set in a sand-box, or inserted in lumps of plastic modeling material, the sand or plastic supporting the parts properly until dry and firm. A continuance of this process will result in a gradual build-up of the vessel until all available parts, if their proper locations can be found, are assembled.

It may be that, in joining the large assembled sections, a good fit may not be attained or that the curves developed in the assembly are not true. In such cases, the previously made unions may be softened by an application of acetone and the now limber sections, as a result, may be eased into proper position or curve. In instances it is necessary

to disassemble sections in order to fit them properly into one unit. This also is accomplished by softening or dissolving the uniting cement with acetone, after which the smaller pieces may more readily be united with the other larger parts already in place.

Granting that the entire vessel is present, nothing more is needed except the removal of undesirable cement on the outer surface. The inner surface may be painted with cement if desired, to give greater strength. If small areas are missing, they may be restored according to subsequent instructions.

### Restoring

The essential requirements in the restoration or reconstruction of pottery vessels are: (1) one or more horizontal curves to determine diameter, and (2) enough of the vertical curve to illustrate the outline from the lip down past the shoulder. With these present, a section representing ten percent or less of the vessel may be sufficient to permit a reasonably accurate restoration.

In the accompanying illustrations an ideal example has been chosen. Enough of the rim is present to project the diameter at the lip (Plate 1). This is accomplished by drawing the outer curve upon a paper and, by normal geometric process, subtending the rim arc in several places (AB and CD) after which centrally placed perpendiculars (EF and GH) are struck, progressing toward a common center. In an ideal specimen the junction of these perpendiculars locates the center of a circle, a part of which is represented by the outer curve of the lip. In most instances, the vessel being asymmetrical, the center is only approximately identified by this method, and a trial and error process with compasses will locate the reasonably true center. In the event that there is not enough of the rim present to thus project the horizontal diameter, it may be possible to use some horizontal curve below the rim. In this case, as long as the location of the curve is noted for subsequent use, the part of the vessel used to obtain this dimension is immaterial. Where it is impossible to draw the desired curves by direct contact with paper, a profile gauge may be employed. Manufacturers furnish instructions for the use of these gauges.

By the use of the above mentioned instrument the vertical profile of the vessel is similarly obtained. As illustrated (Plate 2), a base line (AB) with a perpendicular (CD) is drawn on paper. The profile just obtained is then set up on the base, the distance between the points CE being the radius of the circle prepared in Plate 1. Care must be taken to place properly the "angle" CEG so as to have a correct projection. If this "angle" is too great or too small an incorrectly sized vessel will result. Proper use of the profile gauge will eliminate this possible error.

At point F, located homologous to E, the same profile is drawn with the "angle" CFH equal to CEG. This places the available profile of the vessel properly. The missing base is next drawn in free hand, using graph squares for accuracy. The result is a vertical section of the complete vessel. The basal curve will depend somewhat upon a general knowledge of shape styles for the cultural variety of ware.

The curve DGE, on its base AE, is used for the template shown in Plate 3. This template, shown in solid line, is cut of thin sheet metal, ordinary galvanized iron being satisfactory. After proper dressing to smooth the cutting edge, the template is fastened to a supporting board (shown in dotted lines) with small nails. This board is so shaped that the cutting edge of the metal is exposed beyond the edge of the board.

The curve AB (Plate 3) represents half of the vertical section of the pot. The lip BC is included to assist in clearly defining that part of the vessel in its later stages of restoration. In addition a riser CD is included, after which the base DE rises a bit to allow clearance in the subsequent turning process.

The prepared template is used with the wheel mechanism shown in Plate 4. This mechanism consists of a box with a turn table upon it, along with an upright near the corner. This upright is so set that one of its edges aligns with the center of the wheel. In the center of the box top a short piece of pipe fitted with a base flange is fastened. This serves as pivot for the wheel. A hole of equal size is drilled in the center of the wheel, the latter consisting of five-ply, one-inch, bellow stock. It is supported upon three bearings or casters, and the pivot pipe cut off so that none extends above the upper surface of the wheel. The latter is faced with a sheet of celluloid held by thumb tacks along its outer edge. The under surface may well be faced with sheet metal to prevent scoring.

The template is next fastened to the upright with G-clamps, so that the point "A" (Plate 3) is directly above the center of the wheel, and point "B" the proper horizontal distance from the center. "D" should rest a trifle above the wheel to avoid friction. All is now ready to begin reproduction in clay.

Three or more dowels, placed at the worker's pleasure, are now driven into holes in the upper surface of the wheel, extending upright. These are grouped around the center. Water clay is packed around these dowels, the build-up process continuing until it contacts the template. At this point the wheel is slowly revolved and the excess clay cut off by the template. By continuing with this process, a solid clay form is produced which is the exact size of the original vessel. The template is then removed.

The sherd, or each of several sherds, is next held against the form in its proper place and its outline scratched into the clay. The area so marked is dug out of the form and the sherd inset so that its outer surface continues with the surface of the form. Slight irregularities in the clay are modeled and smoothed by hand. After complete forming, the clay surface is lightly smoothed with a camel-hair brush and water, after which it is lightly flushed with an atomized spray of water. This smooths the surface and gives a pleasing finish to the form. At this point the restoration consists of a solid mass, exactly the size of the finished pot, having the sherd set in proper place.

Little gobs of wax <sup>1</sup> are next applied to the surface of the sherd to serve as anchors, holding the sherd to the mold in a later stage, after which it is primed with a separator such as liquid soap. The clay needs no separator as it serves as such itself.

The preparation of the mold now follows. Ordinary plaster of Paris (gypsum molding plaster) is added to a quantity of water until the water will absorb no more and the mass, when lightly stirred, is smooth and creamy. The mix is slowly poured over the form, encasing it completely with a flowed layer of about  $\frac{1}{4}$  inch in thickness. This is allowed to set firmly, after which a separator of liquid soap or clay water is brushed over its surface and another layer of plaster, similarly prepared, poured over it. Depending upon the size and weight of the clay form, three or more layers may be needed for strength.

When the mold thus prepared is firmly set, it along with the clay and the sherd it encloses, is lifted off the wheel and inverted, after which the clay is carefully dug out. Caution is needed not to disturb the sherd. The mold is subsequently washed thoroughly on the inside to remove any adhering clay.

The next point, that of a separator in the mold, is the subject of much discussion. At the option of the operator, any method he chooses may be employed, but the writer prefers the first: (1) Soaking the mold thoroughly with water and then applying liquid soap to the inner side of the mold, immediately before casting; (2) applying a creamy mixture of stearic acid and kerosene thinly to either a soaking or dry mold; (3) allowing the mold to dry and then painting the inner surface with several layers of shellac and, immediately before casting, applying the stearic acid-kerosene separator.

- 
1. A good composition is: white beeswax, 3 parts; Canada balsam, 1 part. Melt wax and add balsam. Mix. Let cool. Result is soft and sticky.

The casting material, next used, should be prepared previously by sifting together dry plaster and dry color (burnt umber, for example) until the desired shade is obtained. When mixed with water and cast, this preparation will be a bit darker than when dry. The dry color should be lighter than, and readily distinguishable from, the generalized color of the pottery. The admixture of color has a tendency to make the resulting cast chalky; therefore, when a large section is to be cast, a compensator or hardener is needed. This consists of a solution of dextrine in water, the clear solution being decanted for use after undissolved dextrine has settled. For use, the clear liquor is diluted with an equal volume of water.

The prepared color plaster is added to a desired volume of half-strength dextrine solution and very thoroughly stirred. In fact, beating with a wire spoon is excellent. The bowl in which the mixing is done is then tapped and jarred, causing froth and bubbles to rise. This, along with the unmixed color which also floats, is skimmed off and discarded. The rest, a homogeneous mass, is used for immediate pouring, the mold having been prepared with a separator a few minutes before. Depending upon the intensity of the agitation, the setting of the plaster will be accelerated. Usually this takes from two to five minutes.

The plaster is next poured into the mold and the latter rotated by hand so that the entire inner surface is covered by at least a thin layer of plaster. The lip and riser should also be covered. Excess plaster is poured out and back into the mixing bowl from whence, in a minute, it is again poured into the mold and the process repeated. Each time a bit more of the plaster adheres to the mold and the cast is built up. If the mold is very large or if the plaster sets too rapidly, another batch may be prepared and used directly upon the first layer. A small or medium vessel may be cast with one mix of plaster, larger ones needing more. In extremely large specimens, an incorporation of strips of scrim with plaster is advisable to strengthen the restoration. This, however, is rarely necessary. Care should be taken not to cover with the plaster more than the margins of the potsherds.

After the cast has hardened within the mold for two hours, it is safe to break away the latter. This is done with chisel and mallet, one layer being removed at a time, until the cast lies exposed. The rim is now trimmed and the riser removed with a knife. Slight imperfections are filled with additional colored plaster, and the complete cast, trimmed and finished, is washed with water. After drying it is ready for exhibit.

In some instances the greater part of the vessel is present with only very small sections needing restoration. This is simply accomplished by laying a "pancake" of clay in the inner side of the vessel, covering the gap, and filling with plaster from the outside. When set, the excess plaster is trimmed off and smoothed with a knife. Eccentric vessels must be modeled by hand after which the usual molding and casting process is used.

March 23, 1939

Plate 1.

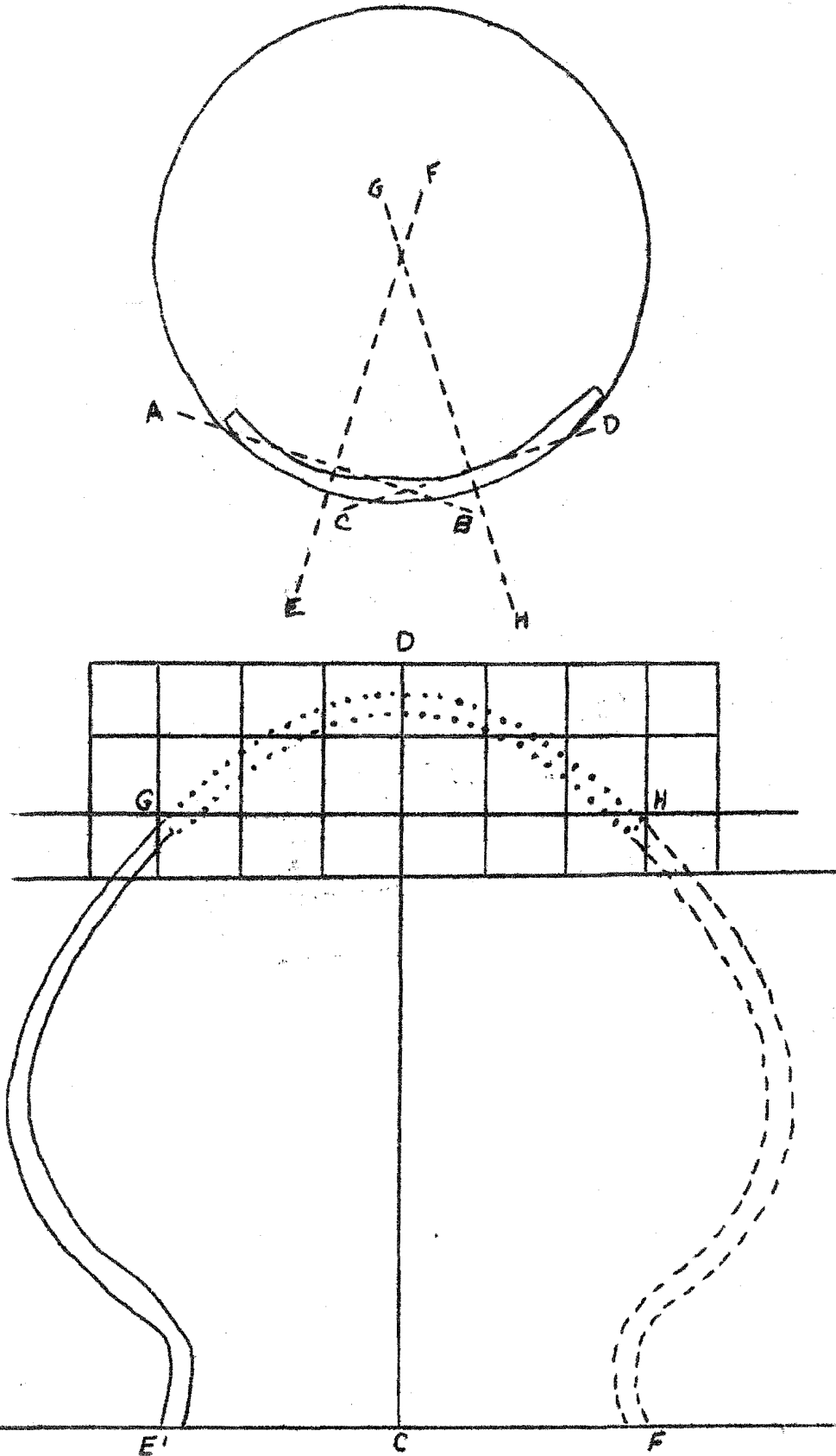

Plate 2.

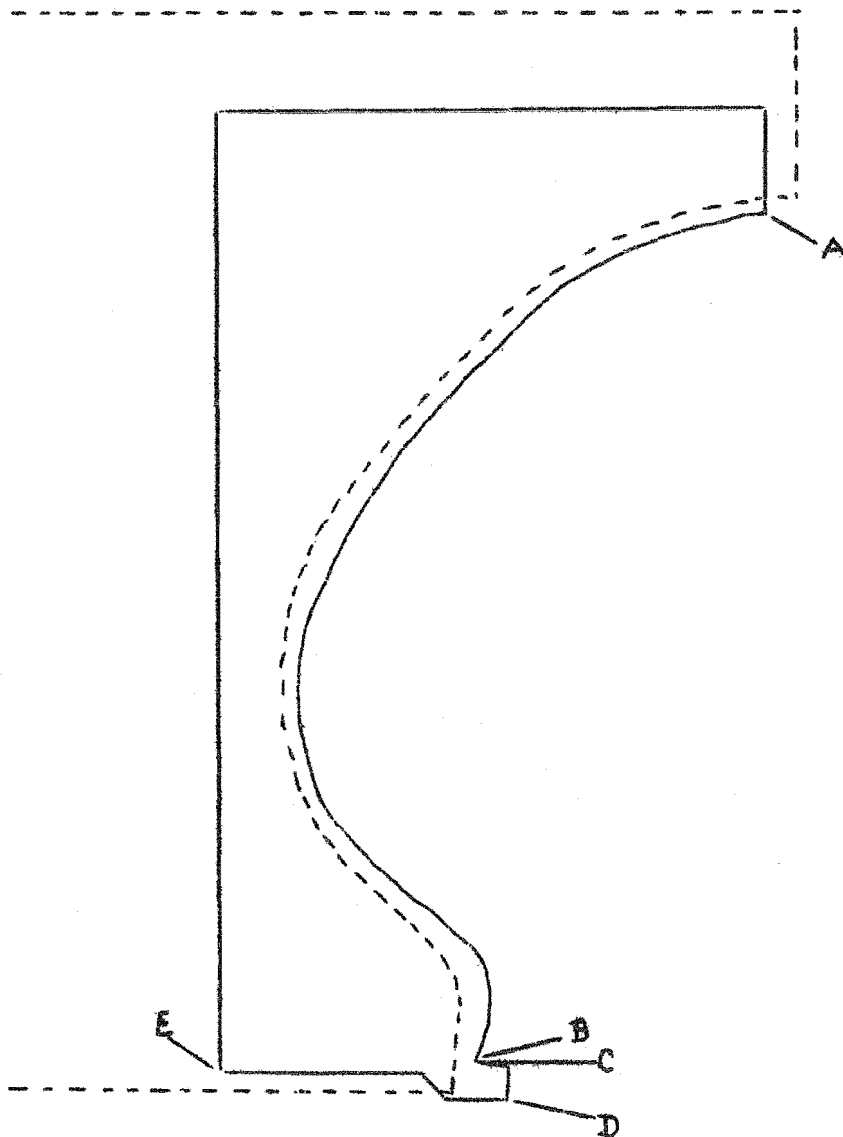

Plate 3



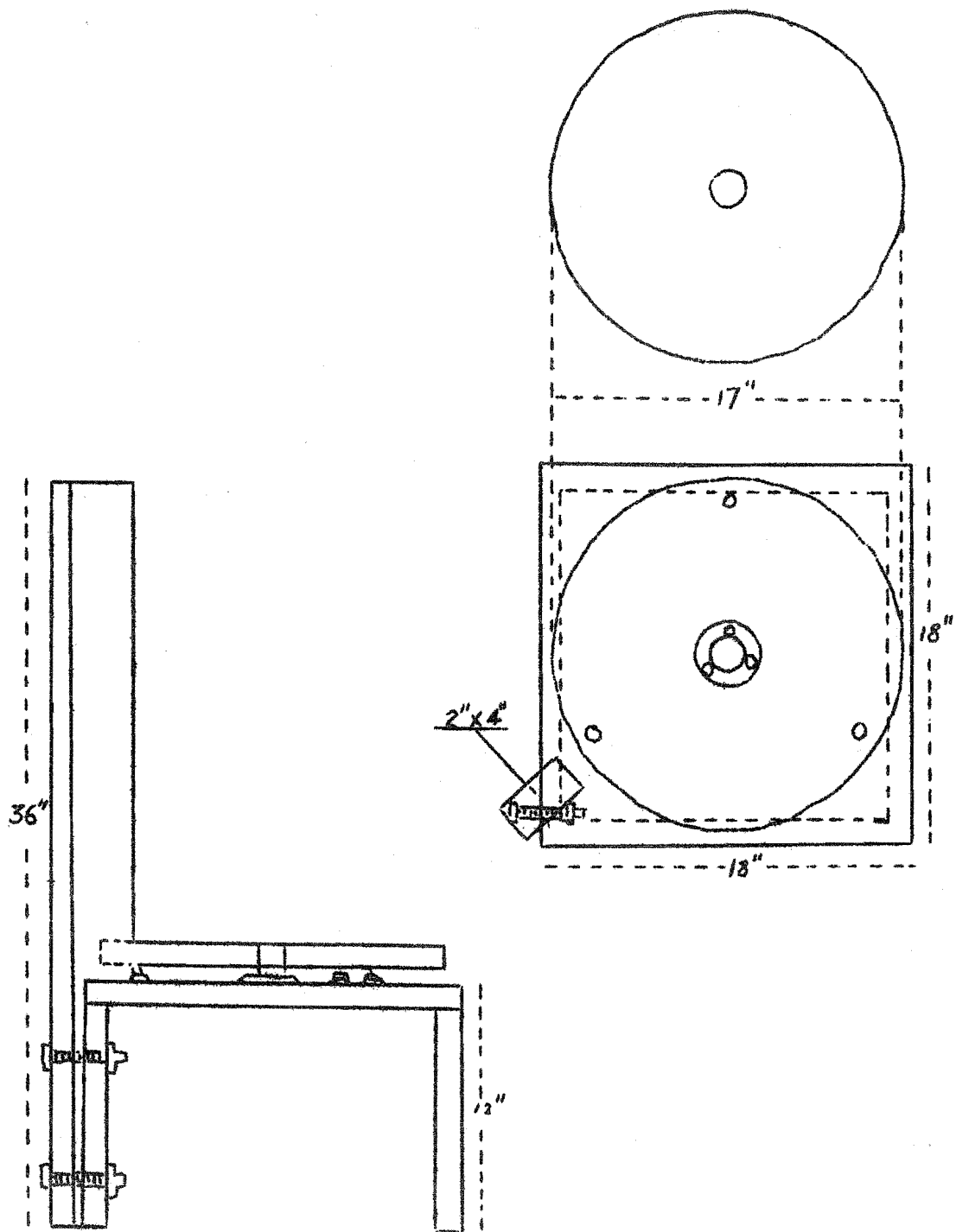

Plate 4.

RANDOM THOUGHTS FROM THE NEW "EDITOR"

Frederick Johnson  
Department of Archaeology  
Andover, Mass.

In taking charge of the Notebook I find myself in an intriguing predicament. Everyone knows that there are many details in Archaeological work which are really fundamental, but in spite of this they really have no place in the ultimate expression of the results of such endeavors. Perhaps it may be said that they are the ropes and pulleys which hold up the scenery before which Archaeology is on view. These "tricks of the trade" have been circulated by word of mouth and many have become most mysterious to those of us who are not able to horn in on the conversation. By providing a medium which, in disseminating this informal information, dispels much of the mystery, the Society has supplied a long desired but previously undescribed need. That the ambitions and accomplishments of the Notebook are of interest and service to all people concerned is attested by the material and comments which have already appeared. However, there is the eternal question, can it be improved? The first stages of experiment have been passed very successfully. I am wondering if it will be profitable to experiment further with the form and content in order that the Notebook may be developed to a point which is of greater service to both contributors and readers.

The Notebook was first published for the purpose of distributing the ideas which came to light during casual discussions of all sorts of problems. More often than not these ideas can be enlarged upon if they can be presented in some informal and unauthoritative way to people who have a different point of view. The Notebook provides a place where nascent theories, perhaps even speculations, techniques, and methods of procedure may be offered for the purpose of acquiring illuminating details.

In effect the Notebook acts as a letter from one person to every individual of the Society. Everyone should reply. Every Archaeologist, no matter what his status or his particular interest, is a confirmed letter writer. I suggest that at least some of this effort be

Society for American Archaeology, NOTEBOOK, Nov., 1939

diverted to the NOTEBOOK so that everyone can benefit from the random thoughts and miscellaneous bits of information which are at present sneaking around in the mail. It should be expected that if an idea needs illumination the general discussion of it in the informal and unauthoritative pages of the Notebook would produce unsuspected and very informative angles -- it is up to you, take your pen in hand!

I ask of everybody what do you want to know? Let me know so that I may have your query mimeographed and broadcast. Somebody will have an opinion and it is more than possible that someone can answer the question to your satisfaction. There may be several answers to your question -- very well, lets argue it out to see what is the best and most acceptable.

There is another question. How do you want the material arranged? Shall I sort out this data and produce numbers which discuss a problem from all angles? Shall I simply publish letters and articles in the chronological order in which they were received? Shall I develop certain headings under which to include contributions? One magazine sometime includes a "Department of Utter Confusion" -- some such Department may not be foreign to Archaeology.

Previous numbers of the Notebook have included a wide range of subjects. Many more can be added with great profit. The whole business of collecting, ranging from a Sunday afternoon in the open to a season's excavation, has been hardly mentioned. The recording of information, upon which our very existence depends, needs further elucidation -- do you have any questions about it; do you have any ideas which may be discussed? How about the classification of the things you find? What system do you use in your catalogue? Does it meet your requirements or do you wish to improve upon it? How do you handle the absorbing task of tracing the distribution of types? We all need information on this important point. Problems connected with Museum technique go on forever. Let us in on some of the swell tricks you have been using to solve even the simplest of your problems. I am tremendously interested in any ideas, comments, criticisms and suggestions which anybody has to offer.

\* \* \* \* \*

LETTERS

Dear Editor:

Mr. Antle's suggestion in the June 1939 edition of the Notebook that the metric system of weights and measures be used in place of the domestic system strikes a responsive chord among many archaeologists including the writer. The domestic system will surely become antiquated, but many of us are too conservative to drop a habit that has impressed itself so thoroughly on our collective minds. A difficulty is visualizing the relation between such basic units as the inch and centimeter and the foot and the meter. It is almost impossible for me to translate the two systems without figuring relationships with pencil and paper.

We all have to be eased into the habit of using the metric system if we wish to follow the lead of scientists in other fields and some archaeologists including practically all of them working in the Old World.

My tendency now is to try to think in terms of both systems. My first step was to begin thinking with those archaeologists that use tenths of an inch -- a sort of bastard system. The next step would be to use the metric system. For purposes of clarity and for those who cling to the domestic system, scales used with photographs and drawings in both the systems could be used. Gradually and painlessly the inertia to change would be overcome and we would begin to find ourselves thinking collectively in the metric system.

Robert McCormick Adams  
742a Forest Avenue  
Webster Groves, Missouri

\* \* \* \* \*

Dear Editor:

Here is a somewhat different method of pottery reconstruction than was illustrated in the last issue of the notes. I think that this method has some advantages, particularly because there is less handling of the original sherds involved.

Society for American Archaeology, NOTEBOOK, Nov., 1939

The set up is the same, that is the manufacture of the template, the determination of the diameter, and the turntable. However, the inside diameter is computed instead of the outside diameter. A clay mold is then made exactly as in the method you have illustrated except that this mold is of the inside of the vase instead of the outside. After this is completed, the original sherds giving the diameter, rim form, and body shape are firmly pushed on to the clay, no other means of holding the sherd to the mold usually being necessary as the wet clay serves as a temporary binding medium. Any other sherds may then be attached whose position in relation to the original vase is questionable. Usually a contour is eventually found into which these sherds fit, although some sherds can never be properly fitted.

The next step, having attached all sherds which are capable of being given exact positions on the contours of the clay mold, is to mix dental plaster until free of bubbles adding water until there is a thin paste. This is then applied to the mold which is not covered by sherds, letting each coat dry. Finally after the thickness of the sherds is reached (and this will be found to vary depending on the position of the sherds), the sherds and plaster are allowed to harden together and the outside mold to become firm. Finally remove the clay contents which will readily peel out and you have the finished product.

The only difficulty with this method, is the danger of some of the plaster running over the sherds. However, this can be easily remedied by coating the surface of the sherds with linseed oil or with soap before the application of the plaster. Also the plaster paste does not have to be watery when applied and can be applied with a small iron spatula working the plaster from the sherd edges towards the spaces between.

Besides offering less wear and tear resulting in trying to remove the clay in the method described in the recent issue of notes, the inside contour offers the advantage of affording the possibility of fitting sherds onto the mold in the method outlined above.

Robert McCormick Adams

\* \* \* \* \*

Society for American Archaeology, NOTEBOOK, Nov., 1939.

## TWO PLASTIC FORMULAS

By H.R. Antle  
Sulphur, Oklahoma

### A Plastic Clay

A year ago I developed a simple formula for a plastic clay which, after several tests, has proven serviceable for laboratory use. Tests include freezing, exposure to drying effects and to summer heat. The latter ranges to as high as 115 degrees in this locality. It was found that a heat in excess of 200 degrees would destroy the base of the clay.

For pottery work, I use a cheap, relatively coarse brick clay as the chief ingredient of the plastic. This results in a rougher cast of plaster molds than would be obtained with a finer clay. This is an especially good quality when one desires to fake in the restoration, preventing the unnatural glaze so often the result in casting. As one knows, pottery surfaces are rough and porous. Brick clay is commonly sold as modeling clay but contains too much grit and lime for fine work. Washing and sifting will improve its quality. A smooth working plastic can be made by using the better grade of modeling clay which is free of grit, lime and iron compounds. A sample I have is white and powdery, giving little lime reaction.

In producing the plastic only two other substances are needed. These are common to any laboratory and are cheap to buy. They are lanolin and glycerine. I do not use more than  $\frac{1}{2}$  of 1 percent of glycerine per volume of lanolin. A crockery bowl is ideal for mixing the plastic. The process is much the same as preparing a stiff dough. Fill the bowl half full of the dry pulverized clay; add small chunks of the glycerine treated lanolin, working the mixture with the fingers. There is no good substitute for the fingers. Work in only enough lanolin to make a crumbly mixture. Knead this awhile; then put the mass up for about twenty-four hours. In this time the base will have carried out its penetration and after additional kneading the plastic will be ready for use. Needless to say, the plastic cannot be worked too much.

My test specimens are still plastic after a year's use. When they are not in service they are rolled into a ball and placed on a shelf which is exposed to room atmospheric conditions. The good qualities of this plastic are, first, it is inexpensive; second, it can be made with quite simple and handy ingredients; third, it can serve for any of the various applications of commercial plastic clays and also act as a fair substitute for gelatin. To substitute for this latter, roll the plastic into a thick sheet, wrap about the object to be cast taking care to press firmly into the surface. Pour a plaster mold about this in the same manner you would for a gelatin mold. Upon removing the object the clay will likely be pulled somewhat out of place but can be carefully pressed back into the plaster mold. Remember this is only a fair substitute for gelatin.

#### A Plastic Wood

A second plastic is similar to commercial plastic wood. This very excellent substitute is made from wood dust obtained in sanding clean wood surfaces. Mix the dust with LePage glue to which has been added a small quantity of grain alcohol. It will serve wherever plastic wood is used.

\* \* \* \* \*

A PROPOSED OUTLINE FOR AN ARCHAEOLOGICAL  
SUBJECT BIBLIOGRAPHY

By H. Holmes Ellis,  
Assistant Curator of Archaeology  
Ohio State Museum

To every student in any scientific pursuit comes one day the realization that in order to achieve the ultimate from his efforts he must systematize and coordinate those efforts. The archaeologically inclined person at some time finds occasion to ask himself, "Where was it that I saw that article on copper awls, or Folsom points, or whatnot?" For such an individual a bibliography serves not as an assistance, but as a life-saver. It would probably be safe to say that anyone who is a serious student of archaeology will at some time compile a list of reference material on a single subject or many.

Early in 1938 a bibliography of American archaeology was started in the Ohio State Museum, using skilled W.P.A. workers under the supervision of R.C. Morgan and the writer. This project is still going on and to date the 3 x 5 reference cards completed occupy the space in thirty, fifteen inch file drawers. Although the vast amount of literature available has not been exhausted, the majority of the important works have been covered. On the basis of this experience a few suggestions to co-workers may be offered.

At the end of this brief statement is an outline for an archaeological subject bibliography. This outline represents a selected list of titles and is not intended to cover every point in the field. It does, however, cover enough of the material to give the average worker some ideas as to how the cards with his reference data might be filed. These titles, or adaptations of them, may be placed on 3 x 5 third-cut blank guide cards, which may be obtained for approximately sixty cents a hundred and in a variety of colors. Choosing one color for main divisions and another for subdivisions of the main titles, serves to make the bibliography that much more usable. If a complete set of guide cards is made out as an initial step, much time will be saved in making out new guide titles and in shifting the guide cards so that they are easily legible.



Society for American Archaeology, NOTEBOOK, Nov., 1939.

For the actual reference cards themselves, white has been found to be preferable to buff or other color. The arrangement of the information on the card is a personal matter, but it should be kept uniform. A typical slip, according to Library of Congress standards, should read:

O

Dustin, Fred

Some Ancient Indian Village Sites in Saginaw County, Michigan. Michigan Academy of Science, Arts and Letters. Papers. Ann Arbor, University of Michigan Press, 1929. v.12, 1929, p.75-93, illus.

The capital "O" above the name indicates that the title was taken from the original article, not from a footnote, bibliography, or other source. At the bottom of the card and on the reverse side is ample space for personal notes on each specific paper.

Although the subject bibliography is probably the most important aid for ready reference, it should be remembered that cross-indexing is also helpful. Duplicate bibliographies by author and by state or area may be compiled in this connection, thereby giving the individual "finger-tip control" of the papers written on a certain subject, locality, or by a given author. A three-way index of this type has proven itself of practical value in the Ohio State Museum.

Agriculture

Anthropology, general

Archaeological Field Work

Subdivided by state & area (Wissler)

Archaeology, general

Archaeological Periodicals

With call numbers of local library

Art

Basketry

Beadwork

Bibliographies

Bonework

Burial Customs

Cache finds

Caves

Celts, Adzes, Axes, Hammers

Cemeteries

Chisels, Gouges, Drills

Chronology

Classification of Implements

Copper	Pre-Columbian Discovery
Implements and	of America
Ornaments	Preservation of Sites
Copper-working	Problematics
Techniques	Projectile Points
Cultural Classifications	Quarries, Location
Early Man	Quarries, Material
Earthworks	Alabaster
Ethnobotany	Argillite
Ethnozoölogy	Flint
Figurines	Jasper
Fortifications	Novaculite
Frauds	Paint
Hearths	Pipestone
Historical Records	Quartzite
Hoes, Spades, Picks	Soapstone
House Types	Stalagmite
Industries	Steatite
Inscribed Tablets	Rock Paintings
Knives, Scrapers	Rock Shelters
Maps	Salt
Metal-Working	Sandals
Methodology	Sculpture
Migrations	Shell Artifacts
Mines: Mining	Shell Mounds
Copper	Stone Age
Gold	Stone Graves
Hematite	Stone Implements
Iron	Subdivided by Area
Jade	(Wissler)
Lead	Stone Mounds
Mica	Stone Ornaments
Obsidian	Stone-Working Techniques
Silver	Symbolism
Turquoise	Textile Arts
Mortar and Pestle	Trails
Mound-Builders	Transportation
Mounds, general	Village Sites
Subdivided by state	Subdivided by area
Mounds, Effigy	(Wissler)
Petroglyphs	Wood-Working
Physical Anthropology	Workshops
Pictographs	
Pipes	
Pottery	

\* \* \* \* \*

REGARDING IMMINENT OR RECENT PUBLICATIONS

By John C. McGregor  
Flagstaff, Arizona

K.M. Chapman is at work on a paper on San Ildefonso design which is to be published as one of the Memoirs of the Laboratory of Anthropology. Bulletin No.7 in the General Series of the Laboratory entitled "Banded Background Blankets", by H.P Mera, and No.8 in the same series, "Dating Prehistoric Ruins by Tree-rings", by W.S. Stallings, Jr., have already appeared. Still another No.9, dealing with Wedge-weave blankets, and prepared by Mera, is in press and will come out shortly. Another Memoir, No.4, "Style Trends of Pueblo Pottery in the Rio Grande and Little Colorado Culture Areas from the Sixteenth to the Nineteenth Century", by Mera, will be ready for distribution early in November.

The report of the 1937 University of New Mexico excavation in the Chaco, (edited by Clyde Kluckholm), is now in the University of New Mexico Press. Hibben is also completing a report on his work in the Gallinas area, which will constitute his thesis at Harvard University.

Dr. R.M. Zingg, of the Anthropology Department of the University of Denver has recently published his "Reconstruction of Uto-Aztekan History".

Dr. H.S. Colton, of the Museum of Northern Arizona, has released Bulletin No.17 of that institution, entitled, "Prehistoric Culture Units and their Relationships in Northern Arizona".

\* \* \* \* \*

Society for American Archaeology, NOTEBOOK, Dec.15, 1939.

NOTICE

The next pages of the Notebook will appear about the middle of February, 1940. Communications should be sent to FREDERICK JOHNSON, DEPARTMENT OF ARCHAEOLOGY, ANDOVER, MASS. Contributions received before February 1st may be included in the next issue, those arriving after that date will be held for succeeding pages.

A Note from the Editor

In distributing this set of pages the Editor has, after some discussion, departed slightly from former custom. Both sides of the paper have been used. By doing this the amount of space has been doubled, but it is a question whether or not it will detract from the appearance, legibility, or general convenience in reading. Your frank criticisms will be greatly appreciated.

The inclusion of abstracts of the papers given at the May meetings are offered in the following pages for the approval of those interested in the Notebook. The principal reason that they have been included goes back to conversations which took place at the meetings. The gist of these were that since many of the papers would not be published it would be a good idea to have some record of them to which reference might be made. There was also the possibility that those who were not able to attend would appreciate a brief exposition of the discussions. This has been done as far as possible. Abstracts were requested of twenty-five people, ten responded and of these two abstracts were withdrawn because the papers are to be published in the near future.

As I look over the abstracts I question whether the membership desires to have this sort of thing published in the Notebook. There is, it seems to me, a possibility that the material is too detailed and at times too abstruse to be of more than local interest. Any discussion of these abstracts or any other matter will be gratefully received. It may be added that communications not intended for publication in the Notebook would be of considerable aid in developing general policies.

Frederick Johnson

Society for American Archaeology, NOTEBOOK, Dec., 15, 1939.

Eighteenth Annual Meeting of the Central Section

AMERICAN ANTHROPOLOGICAL ASSOCIATION

Fourth Annual Meeting of the

SOCIETY FOR AMERICAN ARCHAEOLOGY

May 5 and 6, 1939.

(The following briefs of papers have been received)

Four Prehistoric Populations of the Middle West

Georg K. Neumann, Univ. of Michigan

The present paper is concerned with statistical samples of undeformed male crania of the Spoon River and Maples Mills Foci from Central Illinois, the Indian Knoll people, and the Anderson Village site (Fort Ancient, Ohio) Component of the Fort Ancient Aspect.

Despite the fact that they represent three cultural Patterns and that there is considerable difference in time between the Indian Knoll group and the other two, the series from Maples Mills, Indian Knoll and the Anderson Village site are, morphologically, closely related. Metrically the late prehistoric Maples Mills Focus group of the Woodland Pattern and the contemporaneous Anderson Component group of the Fort Ancient Aspect of the Upper Mississippi Phase can be said to be identical, while the pre-pottery Indian Knoll group from Kentucky differs significantly in a good many characters. Many of these differences are those of size. The Spoon River Focus series falls into a different category.

Generally speaking the affinities of all but the series from the Spoon River Focus are with the Sylvid (1) race. The craniological affinities of another Focus of the Fort Ancient Aspect and the (Middle Mississippi) Spoon River Focus group, though the latter does

---

(1) It seems preferable to use von Eiksted's terms: Sylvid and Centralid and perhaps add Prairid (Plains type) instead of Algonkin, Gulf, and Sioux types, etc. because the latter have linguistic, archaeological or tribal connotations. The Sylvid type is similar to the northeastern dolichocephals of Dixon and Hooton and to Hrdlicka's Algonkin Type.

Society for American Archaeology, NOTEBOOK, Dec., 15, 1939.

not differ too markedly on the metrical side from the Maples Mills Focus group, are clearly with the more brachycranial Centralid race of the Southeast.

\* \* \* \* \*

The Pound Village Site, Elgin County, Ontario

Philleo Nash, Univ. of Toronto

During 1938 a joint expedition of the Department of Anthropology, University of Toronto and the Royal Ontario Museum of Archaeology partially excavated a village site in southwestern Ontario. The following observations are from a preliminary examination of the data obtained.

The site was composed of a dozen or fifteen large refuse piles strung out for half a mile along a narrow, sandy ridge. There were no evidences of fortification. This portion produced remains of a uniform pre-European unstratified culture. There is no evidence that the refuse piles were laid down at the same time. The excavation uncovered vegetable remains, animal bones, a small bone industry, a flaked stone industry, a ground stone industry including slate pendants and one one-holed gorget, grit-tempered pottery decorated with incised and in part stamped designs and fragments of right-angle elbow pipes with flaring bowls. The discovery of a curious deposit of charcoal extending over at least six thousand square feet of an adjoining field led to the hypothesis that there had formerly been erected a pole and bark structure with a hewn plank floor. The suggested structure corresponds most closely to the historic Iroquois long-house.

The Pound site is a deviant Iroquoian site of the western, or Huron-Erie-Neutral type. Its deviations consist of certain Woodland traits in the pottery complex, the predominance of stemmed and notched over triangular, straight-based projectile points, and the presence of a one-holed gorget. These are all listed by various authors as definitive Woodland traits lacking in Iroquois sites. The mixture of Iroquoian

Society for American Archaeology, NOTEBOOK, Dec., 15, 1939.

with Woodland traits suggests the Owasco Phase, but a basic difference requires a separation of the Pound site from the various sites attributed to the Owasco Phase. Owasco sites have predominately Woodland pottery with Iroquoian projectile points; the Pound, Uren, Mason and Alhart have predominately Iroquoian pottery with Woodland projectile points. Perhaps Isle Royal will be added to this list after more detailed study of the Pound material.

\* \* \* \* \*

### A Culture Sequence from Illinois

Horace Miner, Wayne Univ.

The University of Chicago during the last season uncovered at the Kincaid site a clear-cut stratigraphy of three Components. To briefly characterize the Components involved, the cultural manifestation to which all the mounds and most of the surface material can be ascribed is a Component (Kincaid) of the tentative Gordon-Fewkes Aspect of Middle Mississippi. A small amount of non-Mississippi material has appeared. One type including Unionville ware and flint is suggestive of Hopewellian and Adenoid Components. The other is Lewis Component material which includes pottery which seems to resemble the Woodland type.

Excavation of a burial mound during the summer of 1938 exposed these various Components in the following order; In the river-laid silts which form the hardpan of the whole valley were found sherds of the Unionville type. Two feet of sterile clay overlay these pieces, which were probably water-laid. Over the humus capping the clay was a village accumulation which contained nothing but the Lewis Component material. The burial mound was built over the village level. The burials were of a Middle Mississippi people and the mound included a mixture of Mississippi and Lewis pottery. As surrounding surface material was dragged up to cover the burials, the inclusion of Lewis material is not surprizing and need not suggest contemporaneousness. This same sequence of the three cultures is shown at three other parts of the Kincaid site, always in the same order, but nowhere else quite as clearly as at the burial mound.

\* \* \* \* \*

Society for American Archaeology, NOTEBOOK, Dec., 15, 1939.

The Glenwood Focus of the Nebraska

Charles R. Keyes,  
State Archaeological Society of Iowa

During the field season of 1938, with a crew of ten WPA workers it was possible to examine rather extensively the archaeology previously called, in Iowa, the Glenwood. This was apparently connected with a series of earth-lodge sites extending along the bluffs bordering the Missouri River flood plain from the Missouri state line about half way across the western border of Iowa. Eight months of labor brought out a culture so similar to that found in Nebraska as to be no more than a Focus of the same. Apparently the abundant potsherds show a slightly larger admixture of Upper Republican types than do the houses on the Nebraska side of the Missouri, and also there may be slight differences in a few of the traits. As the Iowa sites are most concentrated in the Glenwood Mills county region, the name Glenwood Focus of the Nebraska Aspect seems to be quite clearly indicated.

\* \* \* \* \*

Indian Villages Surrounding the Spiro Mounds,  
Le Flore County, Oklahoma

Kenneth G. Orr, Univ. of Oklahoma

The University of Oklahoma and the Works Progress Administration under the direction of Dr. Forrest E. Clements have excavated the village site directly associated with the mound group at Spiro and a series of related sites in Le Flore County. To date, over twenty village sites have been excavated. The post patterns of seventy-three houses have been worked out and a large collection of ceramic, stone, bone, and shell artifacts as well as skeletal material taken from the villages.



Society for American Archaeology, NOTEBOOK, Dec., 15, 1939.

Nineteen of the villages are culturally related. Their houses are rectangular, 18 by 24 feet, the walls being composed of outside posts placed one foot apart. A central fireplace of baked clay is flanked by two center posts each occurring at equi-distance from the fireplace along the central axis of the house. A post entrance extends from the South wall. The materials from rectangular two center-post houses show a marked similarity to the Caddoan material from North Western Louisiana reported on by James A. Ford. The Louisiana Caddo pottery has exact counterparts in the material from northern Le Flore County. Harrington and Walker's research further supports this similarity. It will be noted, however, that while Ford and Walker's Caddo is historic, the villages in the vicinity of the Sprio Mounds produced no European trade objects.

The mound village directly associated with the Sprio mound group is clearly distinct in both house and artifact types from the Caddoan-like villages. None of the nineteen houses found around the mounds were excavated. The predominant type of house was a rectangular structure with four center posts. Baked clay floors and trench entrances were associated with this type as with the second house type found in the mound village -- a square, four center-post house. A study of the pottery from the village suggests some tie-up with the Marksville-Cole's Creek Caddoan sequence found in Louisiana. It is important to note, however, that Marksville ceramic elements are absent. The presence of Cole's Creek and Caddoan traits further suggests that these sites are affiliated with the later phases of the Lower Mississippi sequence.

\* \* \* \* \*

#### A Hopewell Site in Northeastern Oklahoma

David A. Baerreis, Grove, Oklahoma

The Cooper site, located in Grand River in the northeastern portion of Oklahoma, is a large village site containing abundant refuse. The pottery is grit tempered, rather coarse and also quite thick. Amphora, with a rounded base is the dominant vessel form. Decoration is usually applied in horizontal bands around the rim

Society for American Archaeology, NOTEBOOK, Dec., 15, 1939.

and in alternate decorated and undecorated areas, separated by a trailed line, on the shoulder and body. Techniques of decoration on the rims may be listed as; nodes formed by punching from the interior, diagonal dentate stamping, cross hatching of incised or dentate stamped lines, embossing, and sometimes bordering trailed lines. The rim may be decorated with impressions of cord-wrapped stick, or rows of round or triangular punctate impressions. The various punctate impressions usually accompany either embossing or diagonal rouletting and only in a few instances were found alone. Body decoration usually consists of bands of dentate stamping bordered by a broad trailed line but sometimes takes the form of an oval area of dentate stamping encircled by a trailed line. On the sherds from one vessel the dentate stamping was superimposed to form cross-hatching instead of the usual hachuring. Smooth rocker impressions were also found on the body sherds, though not abundantly.

The chipped stone work was abundant. Stemmed projectile points with an expanding haft either with or without a barb were the only points present in quantity though many stemmed types were represented. Large stemmed knives as well as oval and lanceolate varieties were numerous. Stone drills and projectile points reworked into drills and a few finely chipped axes were present. End scrapers of various sizes and shapes were abundant. Oval manos, shallow metates, and cupstones were found. The only polished stone work were small celts usually only carefully finished near the cutting edge. A small finely polished hematite celt was found.

Worked bone was absent, even most of the bone refuse had decomposed, although the teeth remained to show that the Bison was the principal food animal.

The site, especially in the pottery complex, resembles the Hopewellian manifestations in Missouri, Illinois and Wisconsin.

\* \* \* \* \*

Society for American Archaeology, NOTEBOOK, Dec., 15, 1939.

Progress of the WPA Archaeological Survey  
Project in Kentucky

John L. Cotter,  
State Supervisor, Archaeological Survey  
Project in Kentucky

Work on the WPA Archaeological Project in Kentucky as sponsored by the University of Kentucky was initiated in October, 1937. The Project was developed progressively during the first half year from one unit to seven, employing a total of 270 men, classified as unskilled, intermediate, skilled and clerical workers. Unit supervisors are qualified professional archaeologists or student archaeologists. A laboratory unit is maintained in Lexington where material is processed and recorded as it comes in from the field. Finished data is at the disposal of the sponsors, represented by Major W.S. Webb. The first published report of the Project operations is now in press. It is a study of a shell midden on the Green River and also the problem of the atlatl in the light of new data disclosed.

The following is the record of the Kentucky Project. 32 sites have been completely investigated. They include; shell middens, Adena earth mounds, Fort Ancient Village sites, rock shelters, and various types of mounds and earthworks. 8 sites are being investigated.

\* \* \* \* \*

Symposium on Archaeological Method  
Introductory Statement on Field Technique

Horace Miner, Univ. of Chicago.

The nature of this symposium and the particular subject under discussion precludes any detailed treatment of particular field techniques. Method must always be adapted to the situation so no rule of thumb statement could be possibly made. However, there are certain tendencies evidenced in all our field work which should be brought to light.

Society for American Archaeology, NOTEBOOK, Dec., 15, 1939.

There is an undesirable trend toward provincialism among the various groups in the field. Methods become bodies of knowledge whose originators must defend and promulgate them, good or bad, applicable or inapplicable. Particular groups become known as always applying a single method. To the extent such conditions exist, we neglect our common problem, that of obtaining the most exact and significant record possible. To the extent such conditions do not maintain, the belief that they do exist hinders open cooperation on common problems.

There is a further and related tendency to let techniques become traditional and unquestioned. Our methods are much too new and inadequate to be continued with such complacency. Exact measurements with instruments are combined with "judging" and "guessing" which make the precise procedure meaningless and, even worse, deceptive. Among some of the traditional beliefs, one which might well merit reexamination is our concept of thoroughness in complete excavation. These stereotyped values come to us from work on sites which, by their nature, required complete excavation. Expediency in certain situations make the careful use of trenching and testing both useful and practical. In midden deposits, the analysis of pillars or blocks is even more exact than a sherd count, by levels, of the whole site.

A few general emphases seem important to mention. Some rather exacting laboratory analysis of materials in the field should always be conducted in order to adapt excavating technique to important problems which might not otherwise be recognized in time to get an adequate record. A little forethought into the manner of marking and boxing materials in the field may save hours of rehandling in the final analysis of pottery and artifacts. Lastly, the field man should give greater cooperation to the archaeological specialist in botany, ceramics, zoology, dendrochronology, mineralogy, and history. It should be considered just as heinous a crime to neglect the collection of old wood, clay samples, or the like, as to throw away the excavated cultural material.

\* \* \* \* \*

Society for American Archaeology, NOTEBOOK, Dec., 15, 1939.

(Ed. note; Following this introduction there were a number of prepared statements and some interesting extemporaneous discussion of methods of excavation, recording data, laboratory technique, and final analysis.)

\* \* \* \* \*

### Symposium on Ethno-History

Fay-Cooper Cole, chairman.

For some years anthropologists have been interested in gathering together all possible documentary information relating to the period of contact between Indian groups and Whites on this continent. The major sources for this information lie in manuscript documents and maps, and in the published literature. This field of documentary research has come to be designated as ethno-historic research, meaning the study of peoples through historical sources.

In this area it was realized that a great deal of individual work has been done by institutions and individuals in gathering material of the contact period, but that so frequently the work has been focused on a single element, man, group, or region. The work was usually local or regional and another person following the research would come to a certain point which marked the end of the regional interest and could go no further. Very often duplication of effort and investment occurred where interests overlapped.

This led to calling together in June of 1938 at the University of Chicago a group of historians and anthropologists to consider the problems of ethno-historic research. The group represented the area including Ohio, Indiana, Michigan, Illinois, Wisconsin, Iowa and Minnesota, and formed itself into the Ethno-History Committee of the Upper Mississippi Valley.

It was clear that there was a community of interest between the historian and the anthropologist in any systematic program of investigating all documentary sources, and of copying the pertinent materials, relating to the contact period. Archaeologists are tremendously

Society for American Archaeology, NOTEBOOK, Dec., 15, 1939.

interested in working from the known to the unknown and any materials they can secure which relate to what we now term as archaeological sites, will be of very great value and will give depth to the material we can secure out of the ground. Likewise the ethnologist is much interested in securing all possible ethnographic materials relating to now extinct Indians, and concerning still existing tribes that were in contact with the Whites in this area. It is equally clear that the accounts which are secured of this period are of a great deal of interest to the historian. Similarly these same materials contribute to the disciplines of economics, botany, and so on, and to the specialized fields such as dendrochronology.

It was decided at this conference that cooperation between individuals and institutions within the area was greatly desired. Both the University of Michigan and Chicago were already planning to have two full time searchers working in the field the following year. The University of Chicago project which was underway planned an extensive program of copying manuscript documents by the microfilm duplication process, which in its inexpensiveness makes feasible the copying of large masses of materials. It was anticipated that as many as possible maps would be photostated. In addition, while in the field it was planned that documents which related to marginal areas, or documents which might be considered to be of lesser value and which could await a future copying program, would however be subject indexed, making the knowledge of their existence, location and content readily available. An intrinsic part of the project was the cataloging and analysis of the documents copied during the year, which part of the program is just getting underway.

Each member of the Committee agreed to survey as rapidly as possible the documentary sources of his institution, and of others in his area, and to send an index to the Chairman of the Committee in order that a preliminary listing of materials in the area itself might be made. This was completed in the summer of 1938. It was felt that as soon as possible the most useful plan would be to create a central collection of the manuscripts and copies of manuscripts, relating to the whole area. This collection it was felt should

Society for American Archaeology, NOTEBOOK, Dec., 15, 1939.

be housed in a central clearing house which could act as a point of reference for the entire area. It was hoped that a plan could be evolved so that searchers acting for all the institutions in the area could be put into the field. An ultimate inter-institutional manuscript loan plan was envisioned, as well as a central library, staffed by trained assistants, where all accredited students could work with collections which would be as complete as possible.

(Ed. Note; Before opening the meeting to general discussion three papers were prepared. W. Vernon Kintetz described the uses to which ethno-historical material may be put pointing out in particular how studies in acculturation may be accomplished. J. Jo Finkelstein explained the bibliographical methods which had been developed by the University of Tennessee Ethno-History Project. He described an Ethnology file which was subdivided into a Culture Trait File and a Tribal Culture File and also an Archaeological File which was subdivided into a Site Inventory File, a Culture Trait File and a Site Survey File. Sara J. Tucker commented at length on Archival Search mentioning the scope of the work, the places at which important documents were to be found and methods of recording and cataloging the documents and microfilm copies which were obtained.)

\* \* \* \* \*

Society for American Archaeology, NOTEBOOK, Dec., 15, 1939

COMMENT ON THE WHEELER METHOD\*  
OF RECORDING CAVE DATA

By Harold A. Huscher, Denver, Colorado

During the past two field seasons with the archaeological expeditions of the Colorado Museum of Natural History, the writer was faced with the problem of accurately laying out shelter caves for preliminary investigation without the aid of a formal survey. A satisfactory method was found in a co-ordinate system of gridding which is substantially the same as that described by S.M. Wheeler (Wheeler, S.M., RECORDING OF CAVE DATA, This Journal, Vol. IV, pp.48-51, 1938), differing chiefly in details of cataloging and in the use of metric, rather than English, measurements. The larger projects, such as excavations of ruins, mounds, etc., obviously require mapping and regular checking by a professional surveyor, but the Wheeler system has been found particularly easy to use in laying out, without instruments, small caves and rock shelters for trenching, test-holing or even complete excavation. The gridding and mapping can, of course, be done more efficiently with a transit, but any reasonably intelligent laborer can do entirely accurate work with nothing more than a steel tape, an ordinary mason's level, plenty of stakes, chalk line, and frequent reference to the Pythagorean rule of 3-4-5.

Actual use in the field has suggested minor changes in the plan, whether these were used by Wheeler was not made clear in the original note. Back walls of shelter caves are often very irregular and the deposits are also highly unpredictable, thus it easily can happen that the plotted excavation must be extended in unexpected directions. Backward and forward extensions of the grid may be facilitated and re-numbering and re-cataloging kept to a minimum by first mapping the back wall in relation to a survey base-line or temporary axis of abscissas ( $x'-x'$ , Fig.1) set up parallel to the axis of the cave and as far forward as practicable (this will usually mean the front edge of the shelter floor), then lettering from an imaginary axis of abscissas ( $x-x$ ) established one or more survey intervals (meters,

---

\*Wheeler, S.M., Recording Cave Data, Amer. Antiq. Vol.IV, pp.48-51, 1938.



Society for American Archaeology, NOTEBOOK, Dec., 15, 1939.

yards, etc.) back of the actual cave wall (w-w). In the case of an almost-filled shelter-cave the wall may be found to slope further back as the digging progresses. The one or two meter (yard) allowance will ordinarily take care of this slope. In the case of stratified debris extending forward over the rim of the shelter floor or possibly down the talus slope, lettering from the back allows the addition of as many squares as necessary without altering the letters in the originally plotted area.

Measurement of depth is another point in question. Depth is usually given from the 'surface', but, especially in the arid southwest, the surface is not necessarily constant. In a deposit where careful stratigraphic sections must be drawn it is imperative that a surface profile be made for each row of squares before any digging is done, because trampling of the surface loosens and shifts ash, sand and small pebbles, and the wind rapidly carries away the finer material. The error so produced may run into inches with only a few windy days, and that great an error could easily invalidate the attempted relocation of specimens. An example of the vital necessity of some absolute system of measuring depths is shown in Fig. 2a, an actual stratigraphic section from the Moore Shelter. Disturbance of the loose dung layer, even though it is only a few centimeters deep, could create sufficient error to completely invalidate the attempted laboratory re-location of an artifact. The stratigraphy in the present instance was particularly clear which would make any error inexcusable.

Here the remedy lies in plotting the surface profiles, the depths of each stratum and the depth of each artifact, in relation to an above-surface grade-level (actually a chalk line stretched between stakes, at datum level or at a known distance above or below datum level). Then the exact provenance of a given artifact can be located, at any future time, on the stratigraphic section drawings, and the true depth can be computed by taking the distance between the original surface and the grade-level and subtracting this amount from the over all depth.

Society for American Archaeology, NOTEBOOK, Dec., 15, 1939.

Knowing the original surface is a great aid in the sad case of a particularly productive 'lode' running back under the spot selected for a dump pile.

In the case of excavations in deep caves, or in long and crooked or segmented shelter caves, the grid would probably best be broken up into separately lettered sections (Section A, Section B; just as Trench A, Trench B, are used). A survey 'traverse' of the cave as a whole should first be made, then selected 'stations' of this traverse may become datum points for the individual grid sections. Thus the 'dig' is bound into a consistent whole, but location of any one artifact requires considering only the comparatively short distances of its section.

For those who have never had occasion to survey a site without instruments a suggested outline of procedure follows:

From any two points on the back wall (w-w) which seem to be on the axis of the cave, measure forward at right angles an equal distance (w-p, w-p) and drive stakes. Any convenient distance will do, but try to get well forward of the actual working area. A line through these two stakes (x'-x) is now the surveying base-line or temporary axis of abscissas (in deep caves use instead the line of traverse; the procedure is the same in either case). Drive stakes along this line at the selected survey interval (1 m., 1 yd., 2 yds.) and hammer them down to an even level. If the surface is too uneven you may have to break the line up into two or more levels. If the surface is stony some stakes may have to be omitted or may be offset some known distance in a convenient direction. Stretch a chalk line along this line so as to cross each stake, re-check the intervals and fix the exact measurements by driving a tack in the head of each stake.

From each of these stakes measured perpendiculars are dropped to the back wall and plotted on cross section paper; a line through the ends of each of these perpendiculars will map the outline of the cave wall in relation to the survey base-line. To insure accuracy the angle of every third perpendicular (at

Society for American Archaeology, NOTEBOOK, Dec., 15, 1939.

least) is checked twice, once from each side, by the old rule of 3-4-5, i. e. measure three units along the survey base-line from the intersection to be checked, measure four units along the ordinate, then the hypotenuse should be five if the angles are true (Fig. 25). Measuring off the survey intervals on these perpendiculars completes the grid. The intersections, of course, should all fall into straight lines parallel to the base-line and therefore to the imaginary axis of abscissas.

Excepting where rockfalls interfere, stake as many of the grid intersections in the working area as you have stakes for, and believe me, if budget and transportation means allow take plenty of them. In the long run stakes are cheaper, easier to use and more satisfactory than transit readings, and you'll never regret staking each interval. There is nothing more annoying than to have stakes kicked over or caved away necessitating continual measuring back to some distant reference point. At all events, stake each interval all the way around the area scheduled for excavation, then any surface point may be re-located by crossed chalk lines even after the surface is dug away.

On the cross-section paper which shows the back wall extend each perpendicular beyond the wall and set up the imaginary axis of abscissas (x-x) one or more survey intervals back of the deepest alcove of the wall. Select some perpendicular well to the left (facing the wall) of the work zone for the axis of ordinates and you are ready to number the squares. Use numbers on the long axis of the grid and letters on the short; the average person can see the relationship between widely separated numbers when the corresponding letters would baffle him.

\* \* \* \* \*

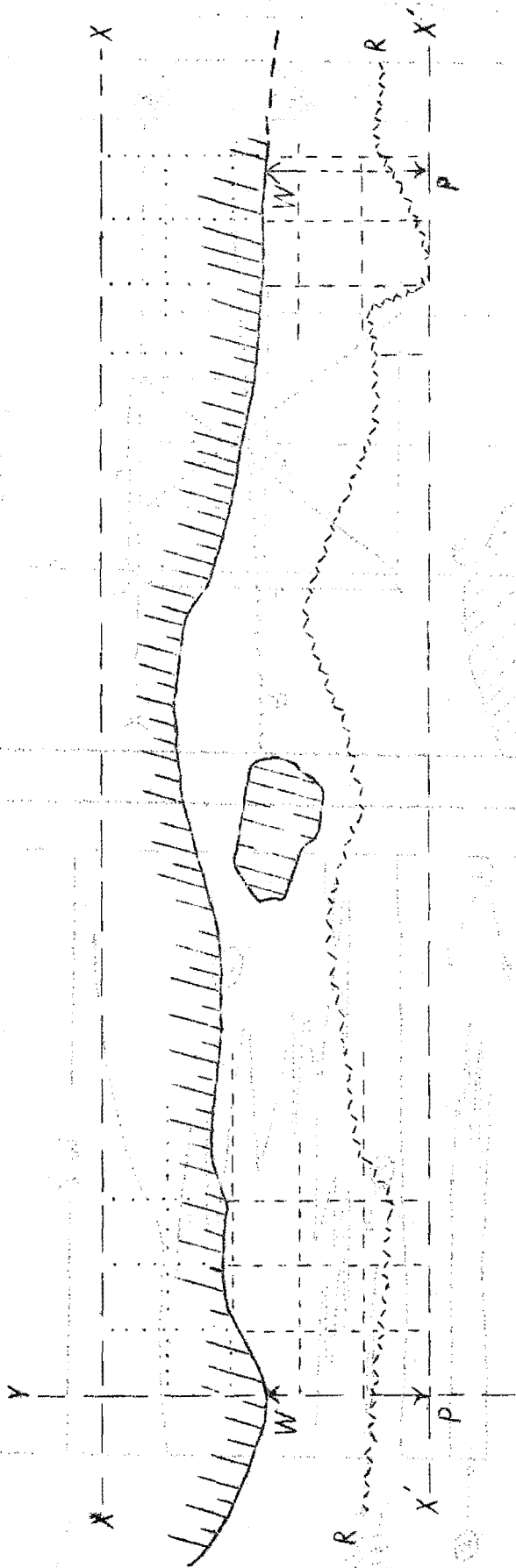

FIGURE 1

